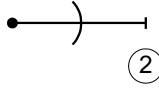
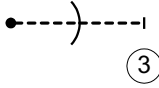
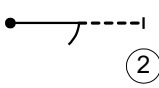
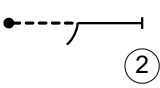
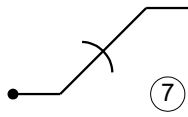
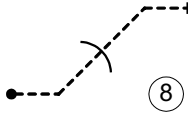
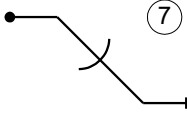
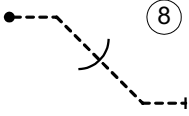
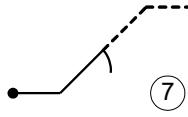
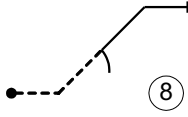
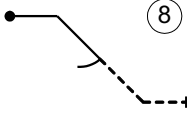
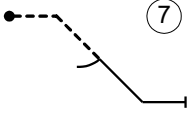
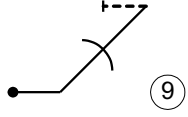
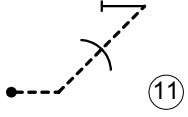
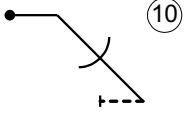
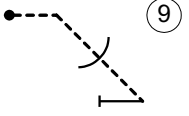
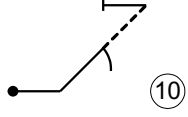
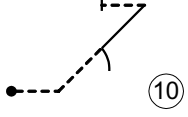
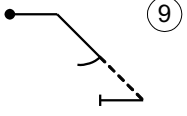
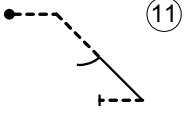
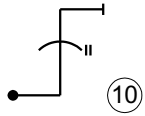
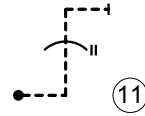
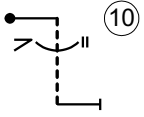
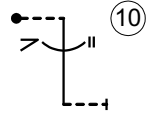
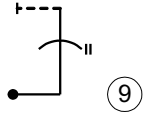
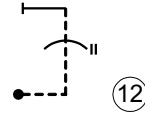
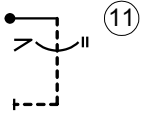
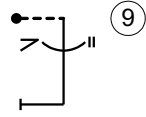

FAMILY 1 – LINES AND ANGLES

ARESTI AEROBATIC CATALOGUE (CONDENSED)

Family 1.1. Single Lines

1.1.1				
1.1.2				
1.1.3				
1.1.4				
1.1.5				
1.1.6				
1.1.7				
	1	2	3	4

FAMILY 1 – LINES AND ANGLES

ARESTI AEROBATIC CATALOGUE (CONDENSED)

Family 1.1. (Cont.)

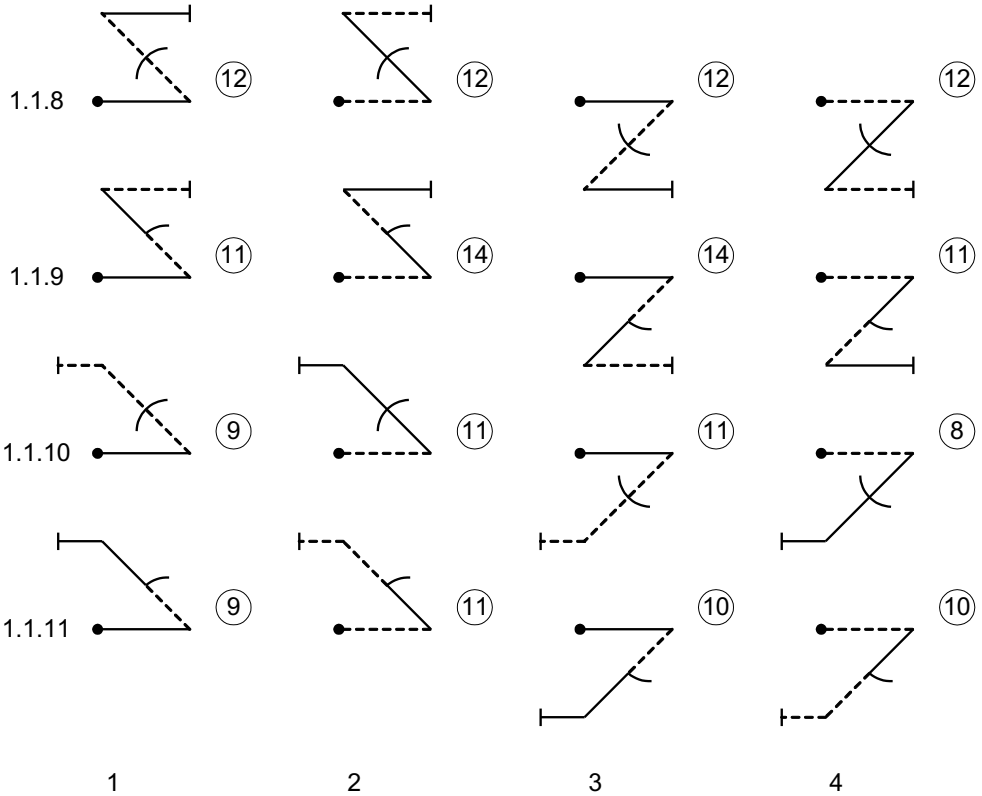

FAMILY 1 – LINES AND ANGLES

ARESTI AEROBATIC CATALOGUE (CONDENSED)

Family 1.2. Two Lines

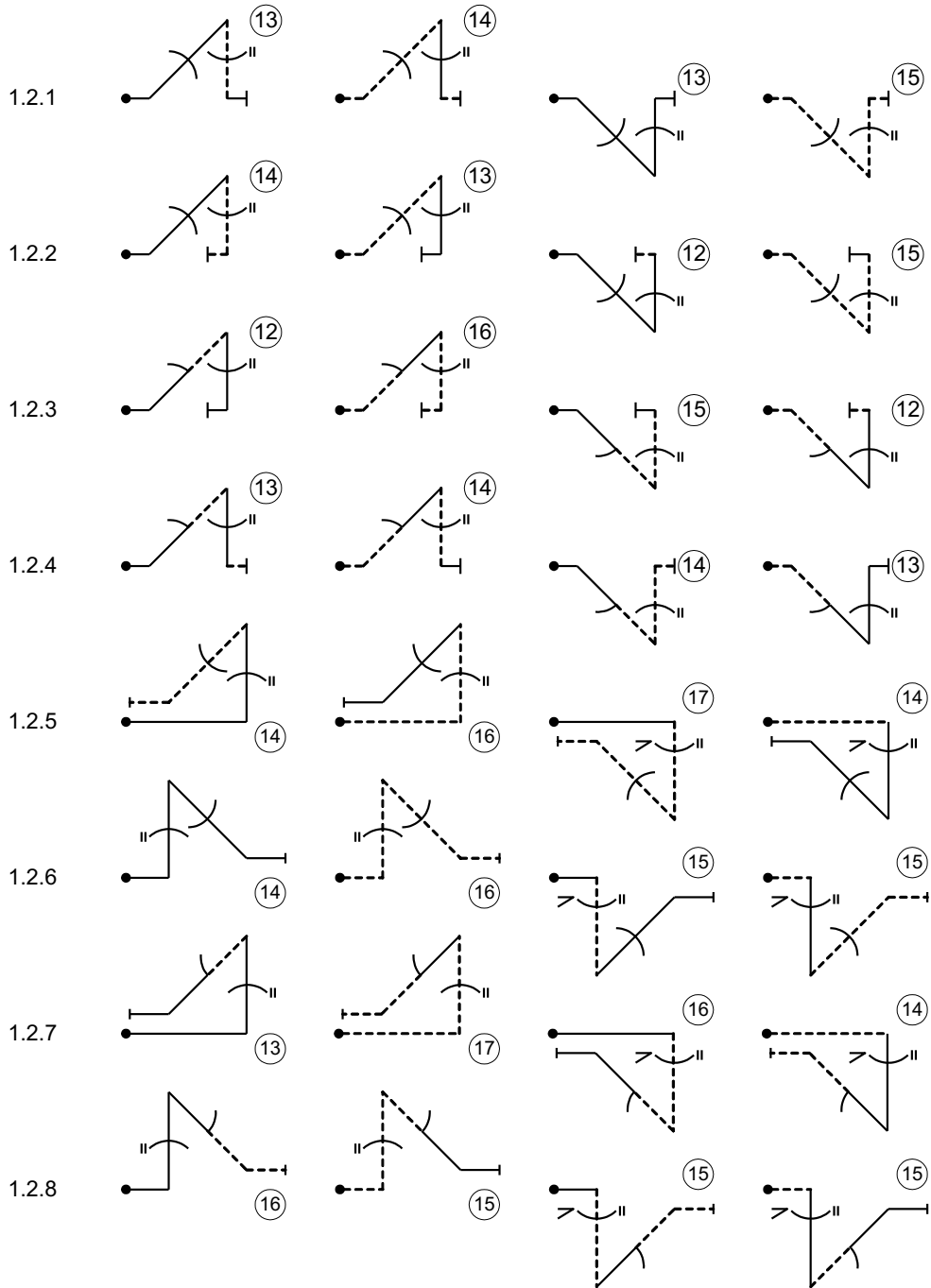

1

2

3

4

FAMILY 1 – LINES AND ANGLES

ARESTI AEROBATIC CATALOGUE (CONDENSED)

Family 1.2. (Cont.)

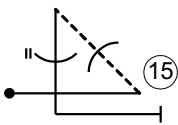
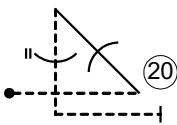
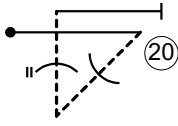
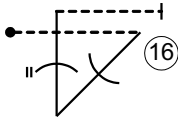
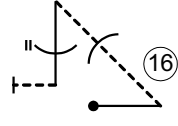
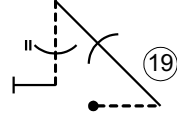
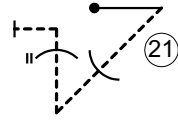
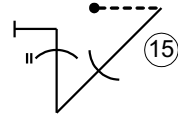
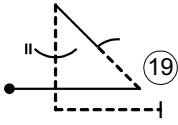
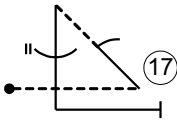
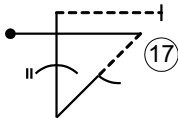
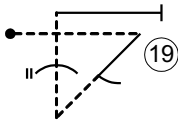
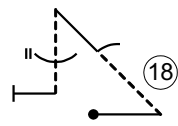
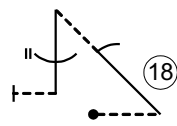
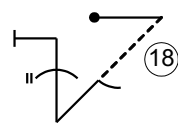
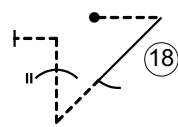
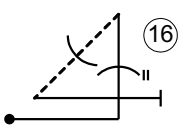
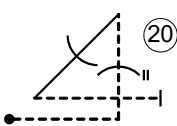
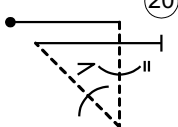
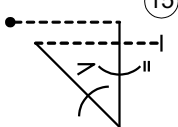
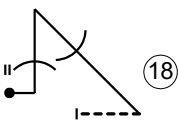
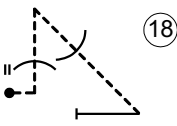
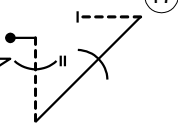
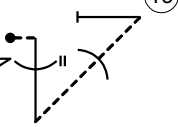
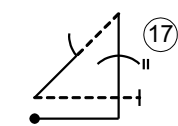
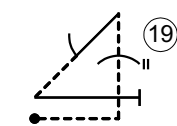
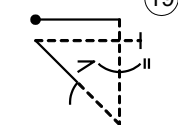
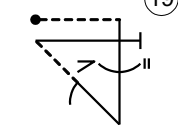
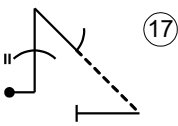
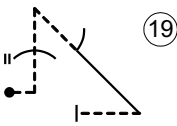
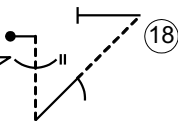
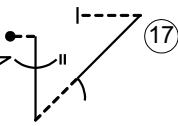
1.2.9				
1.2.10				
1.2.11				
1.2.12				
1.2.13				
1.2.14				
1.2.15				
1.2.16				
	1	2	3	4

FAMILY 1 – LINES AND ANGLES

ARESTI AEROBATIC CATALOGUE (CONDENSED)

Family 1.3. Three Lines

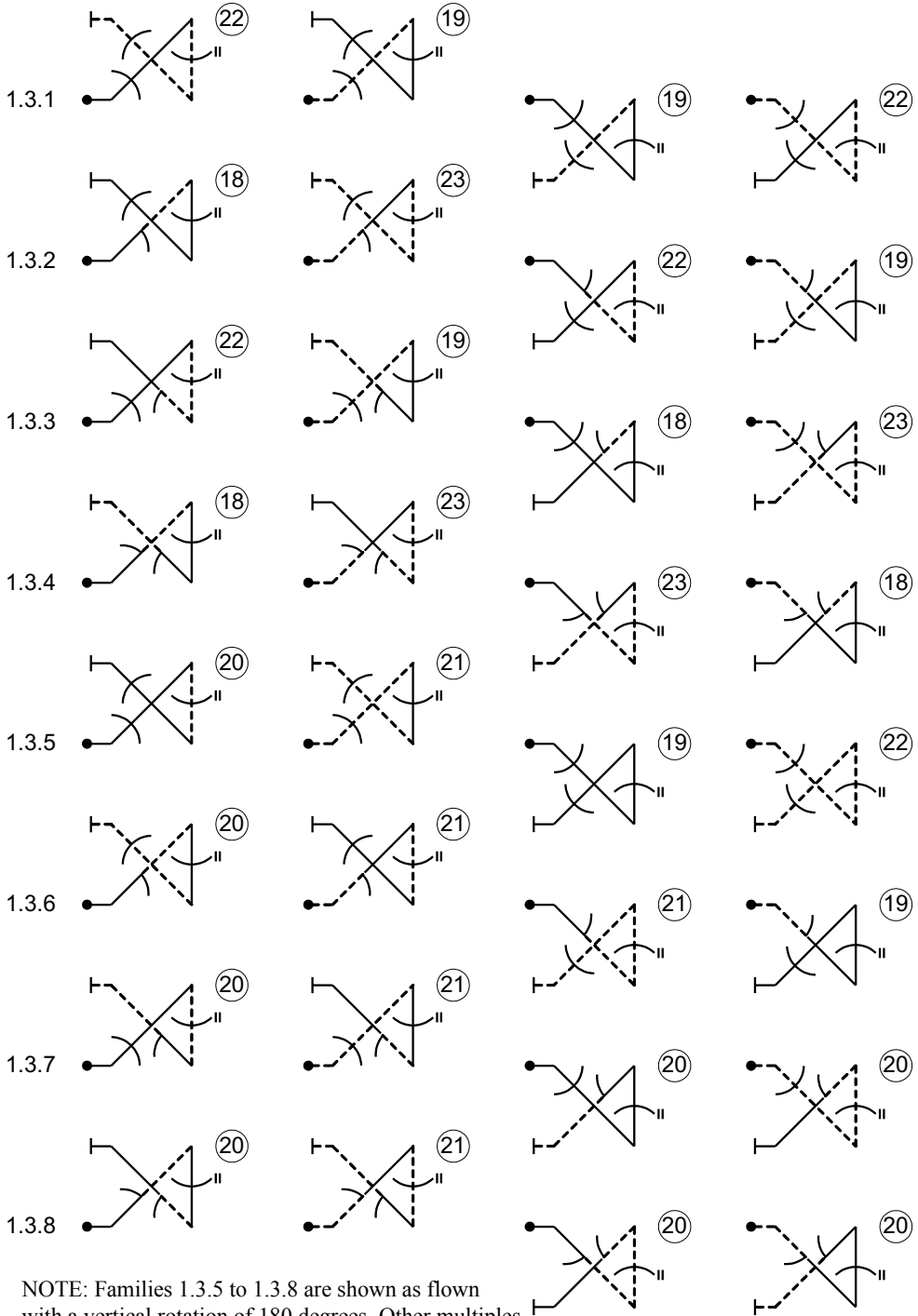

NOTE: Families 1.3.5 to 1.3.8 are shown as flown with a vertical rotation of 180 degrees. Other multiples of 90 degrees of vertical rotation are permitted.

FAMILY 1 – LINES AND ANGLES

ARESTI AEROBATIC CATALOGUE (CONDENSED)

Family 1.3. (Cont.)

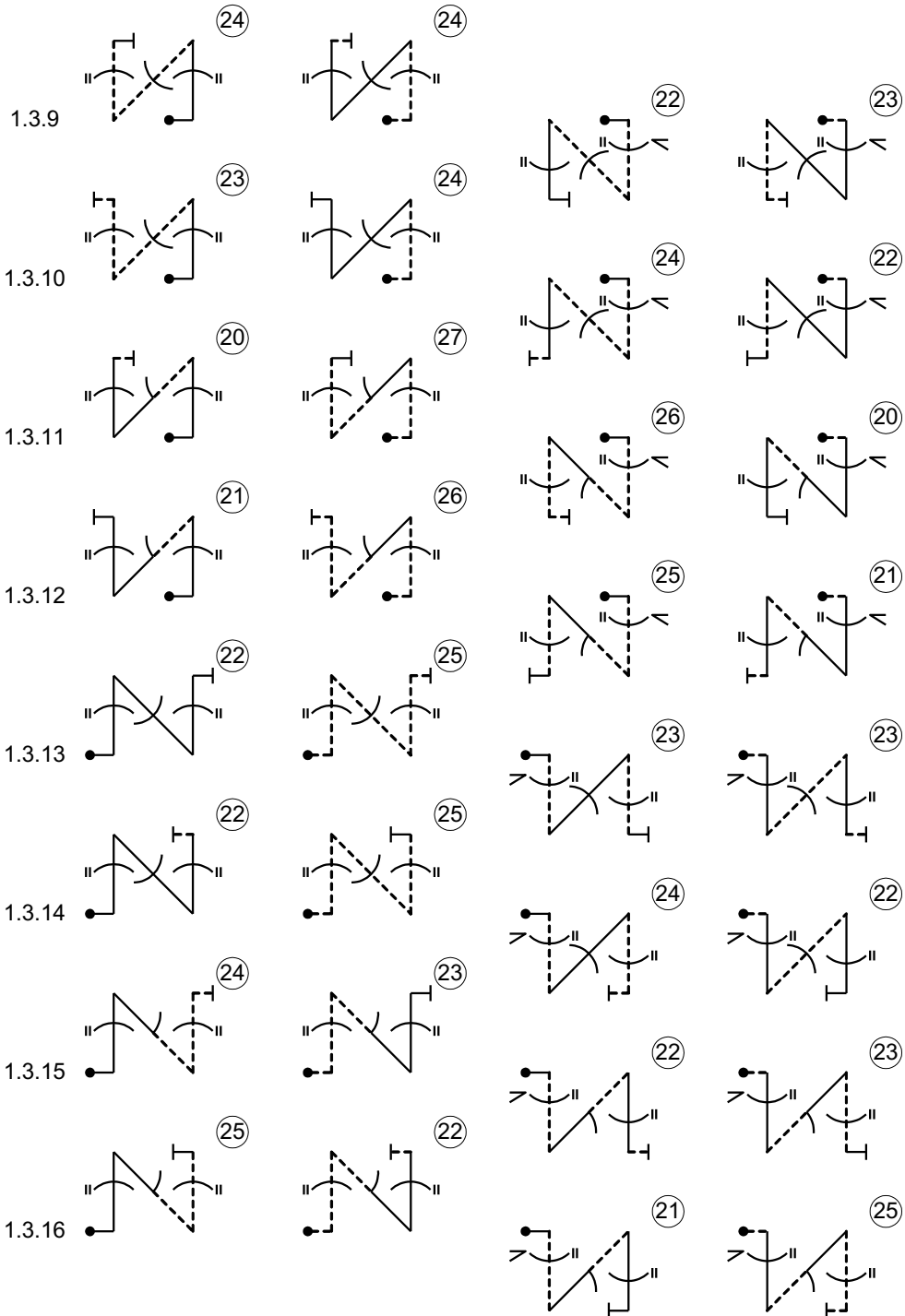

FAMILY 2 – TURNS AND ROLLING TURNS

ARESTI AEROBATIC CATALOGUE (CONDENSED)

Family 2.1. 90° Turns

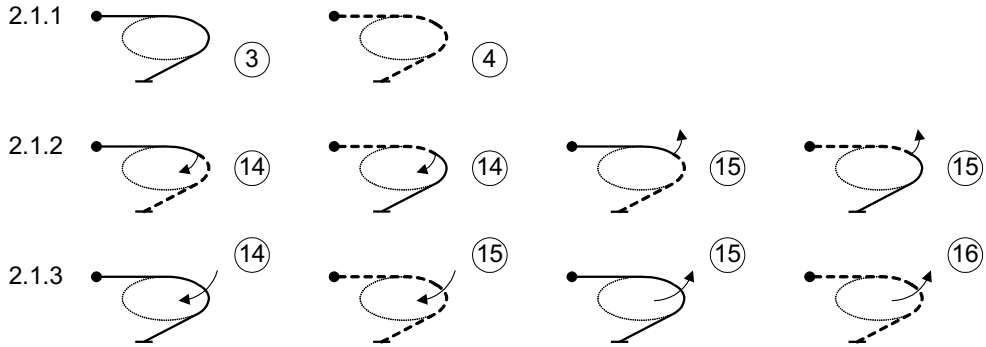

Family 2.2. 180° Turns

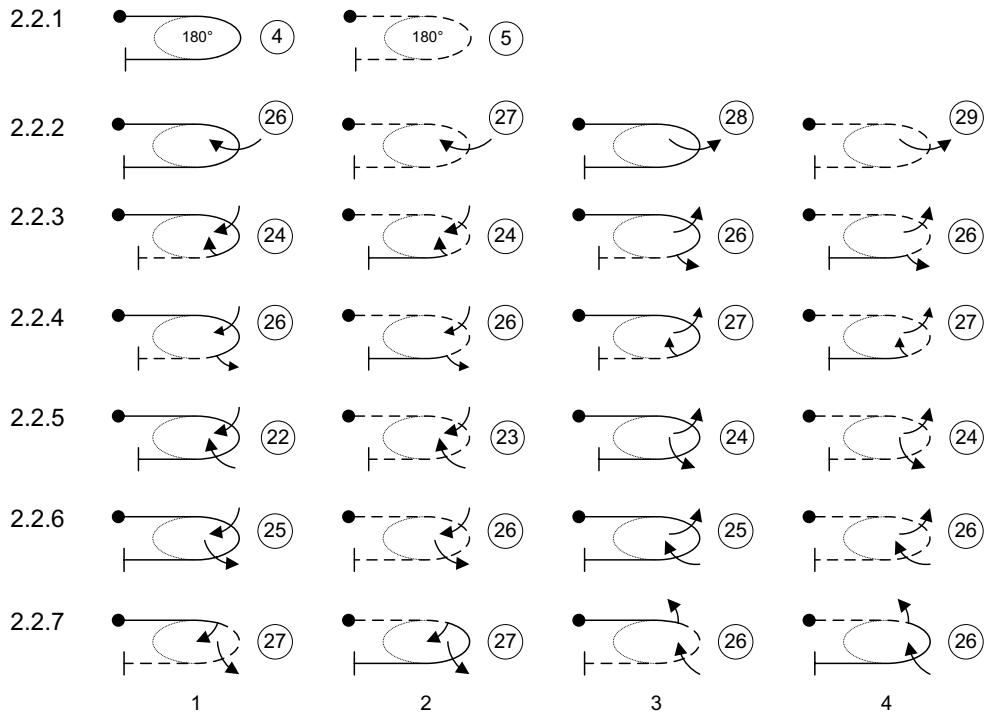

FAMILY 2 – TURNS AND ROLLING TURNS

ARESTI AEROBATIC CATALOGUE (CONDENSED)

Family 2.3. 270° Turns

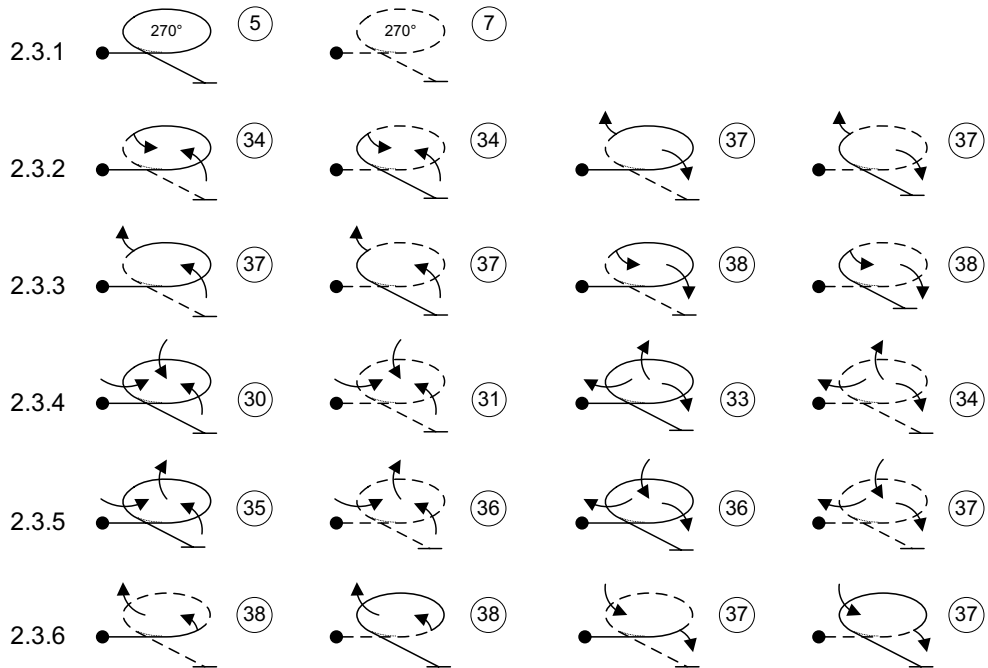

Family 2.4. 360° Turns

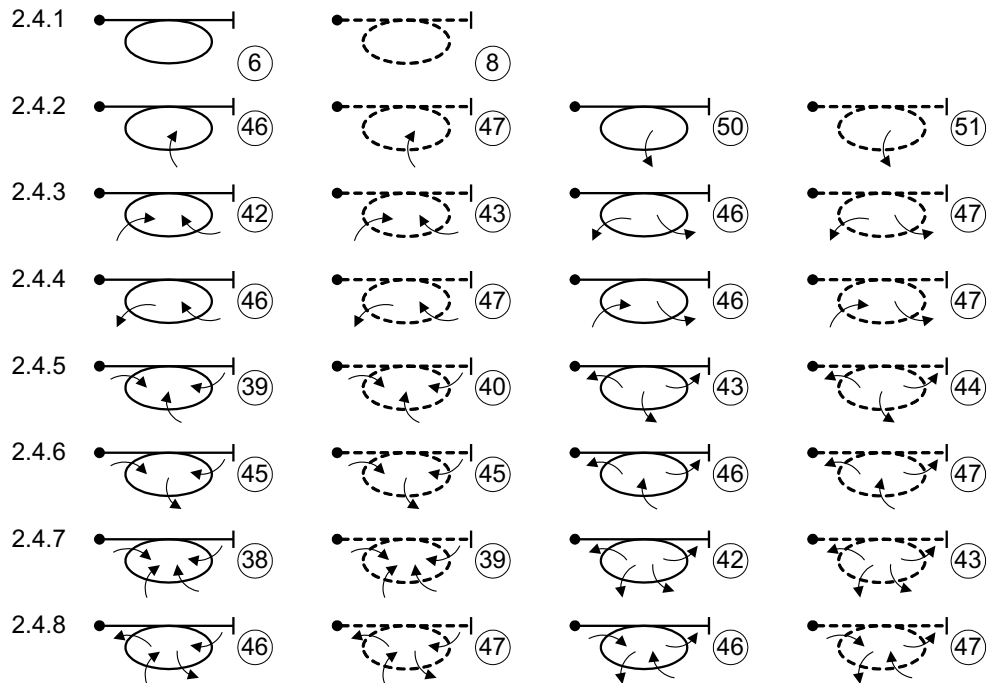

1

2

3

4

FAMILY 3 – COMBINATIONS OF LINES

ARESTI AEROBATIC CATALOGUE (CONDENSED)

Family 3.3. Three Corners

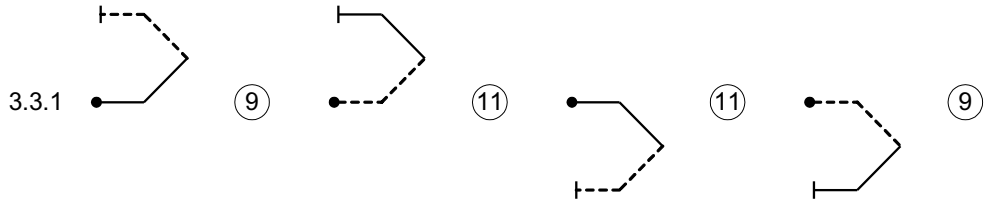

Family 3.4. Four Corners

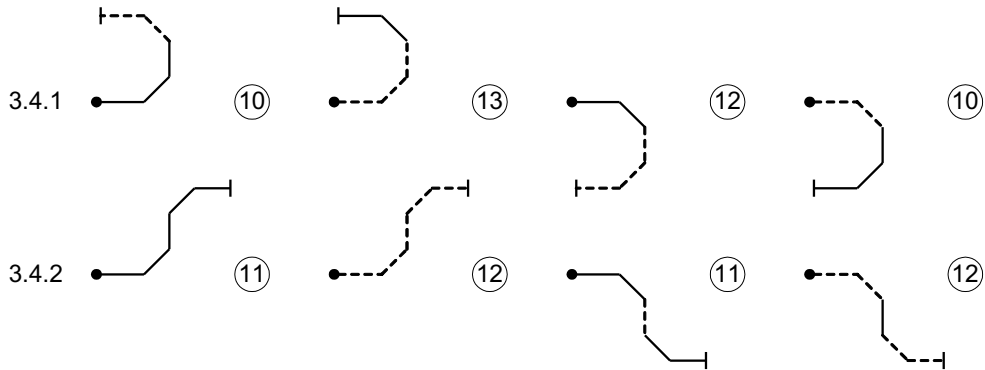

Family 3.8. Eight Corners

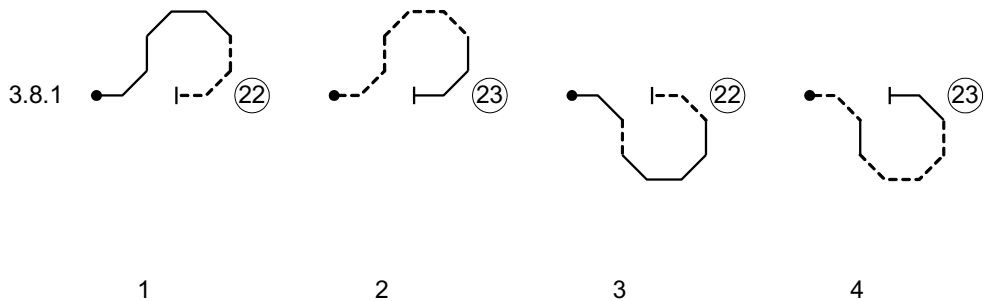

FAMILY 5 – STALL TURNS

ARESTI AEROBATIC CATALOGUE (CONDENSED)

Family 5.2. Two Line Stall Turns

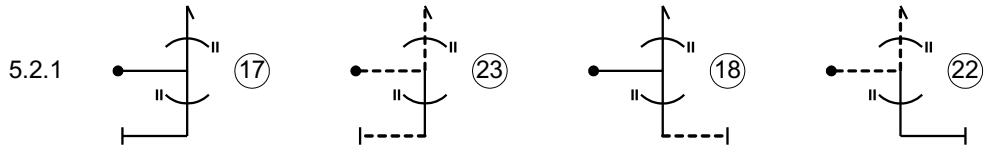

Family 5.3. Three Line Stall Turns

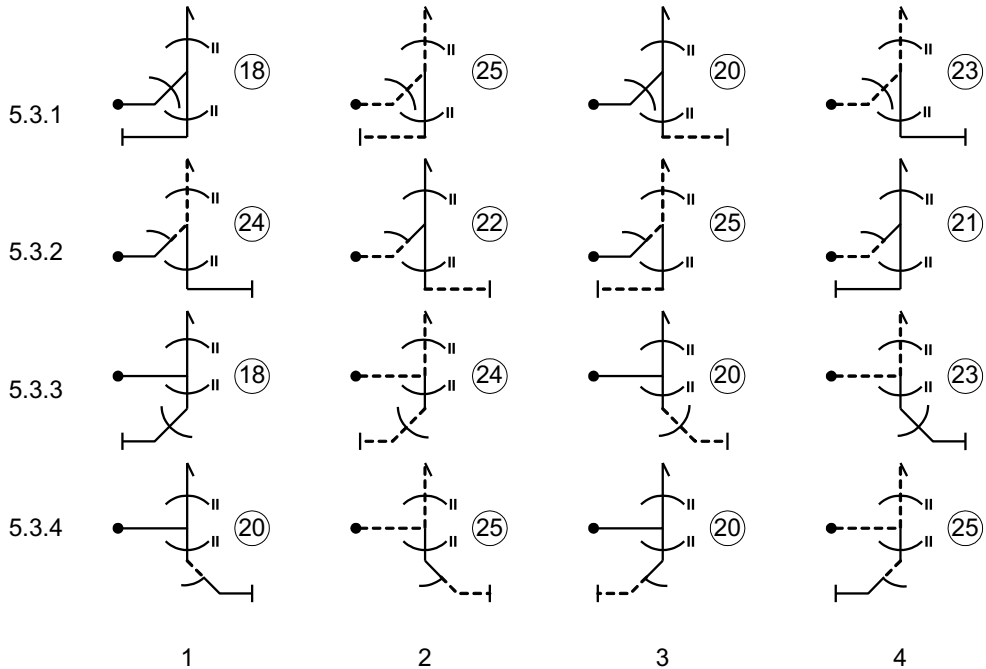

FAMILY 5 – STALL TURNS

ARESTI AEROBATIC CATALOGUE (CONDENSED)

Family 5.4. Four Line Stall Turns

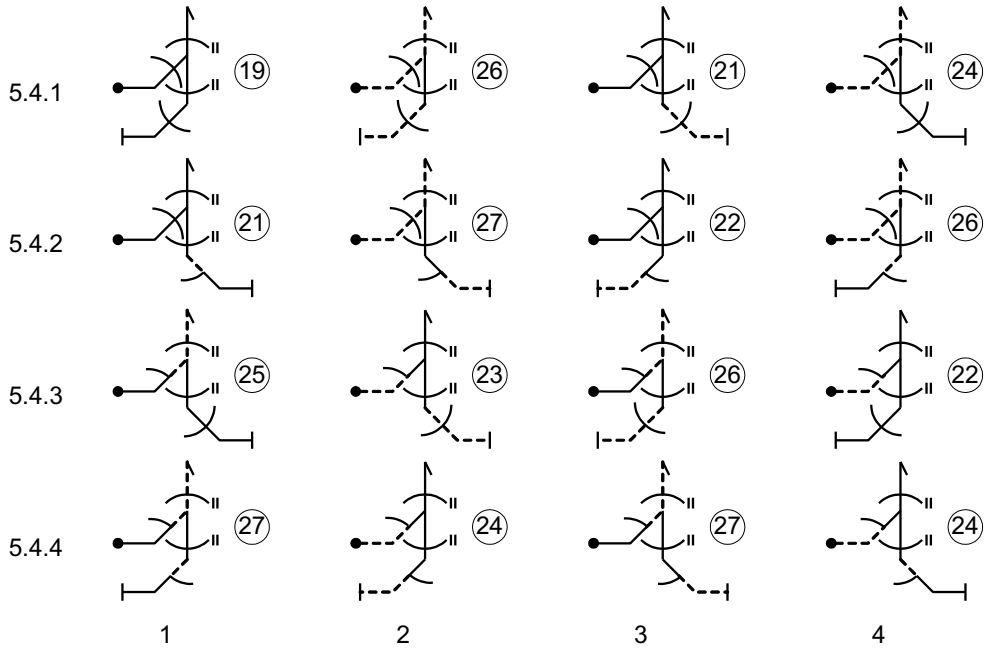

FAMILY 6 – TAIL SLIDES

ARESTI AEROBATIC CATALOGUE (CONDENSED)

Family 6.2. Two Line Tail Slides

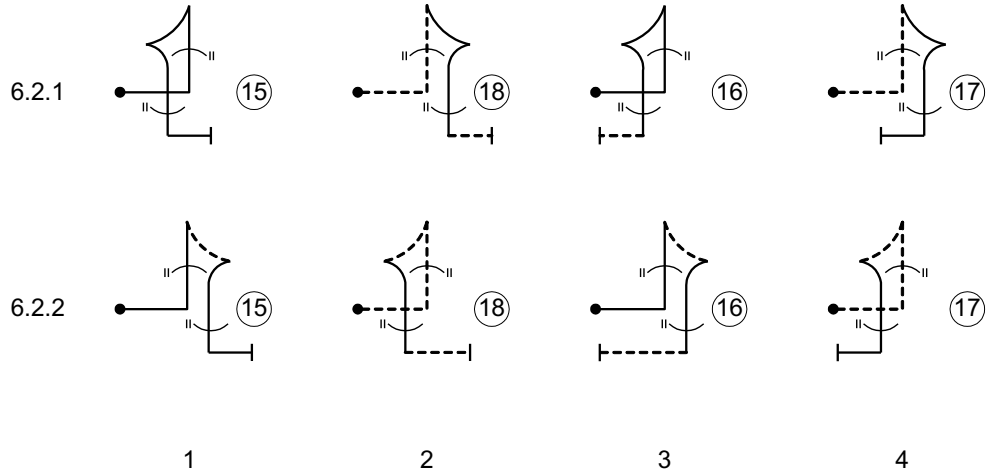

FAMILY 7 – LOOPS AND EIGHTS

ARESTI AEROBATIC CATALOGUE (CONDENSED)

Family 7.2. Half Loops

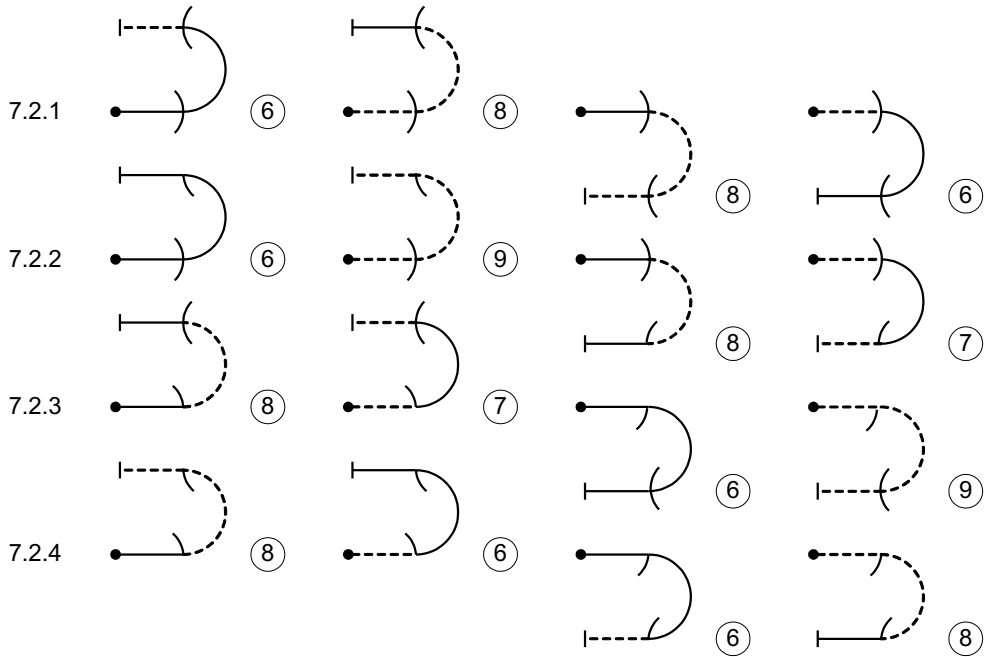

Family 7.3. Three Quarter Loops

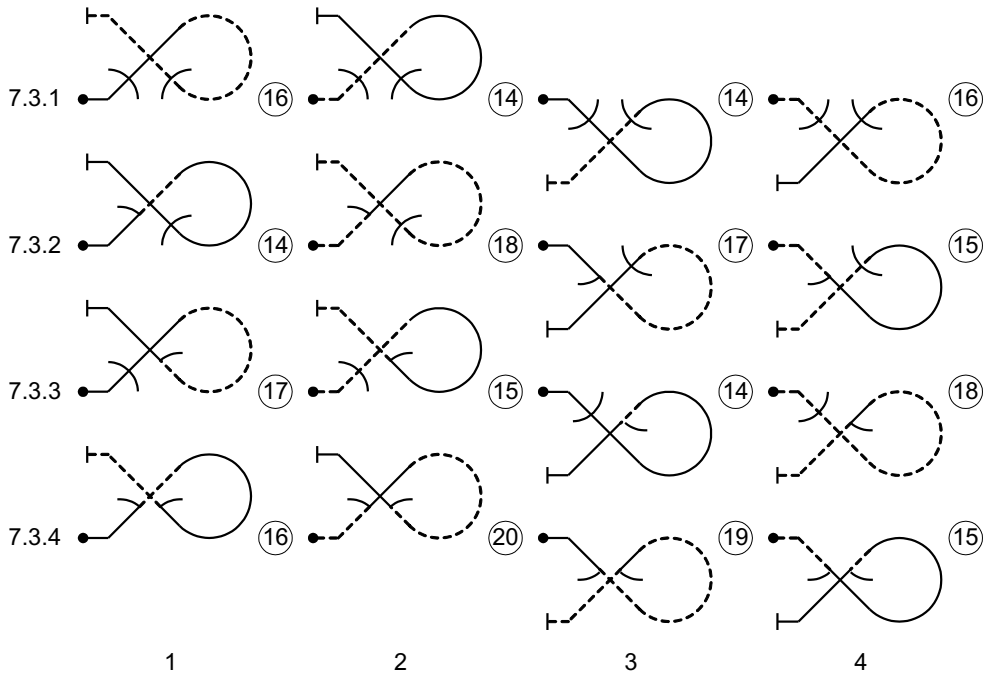

1

2

3

4

FAMILY 7 – LOOPS AND EIGHTS

ARESTI AEROBATIC CATALOGUE (CONDENSED)

Family 7.4. Whole Loops

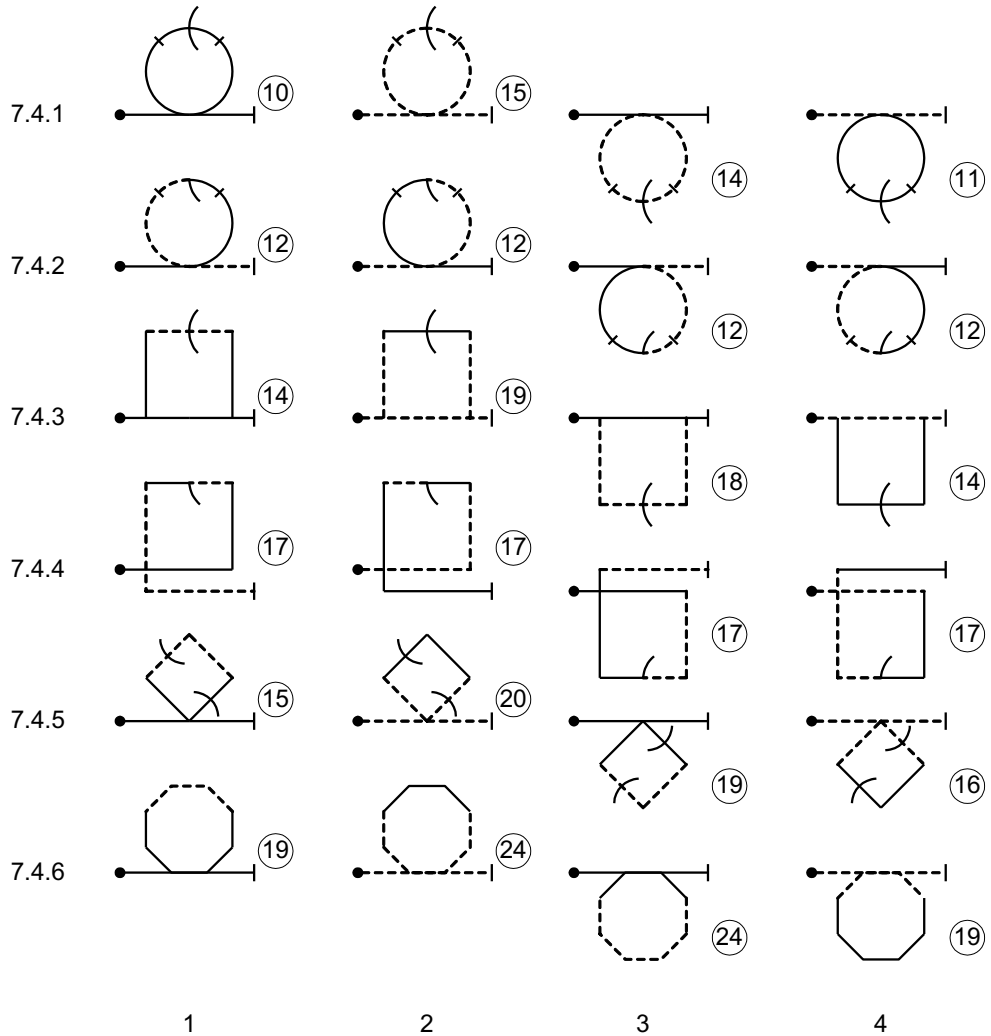

FAMILY 7 – LOOPS AND EIGHTS

ARESTI AEROBATIC CATALOGUE (CONDENSED)

Family 7.4. (Cont.) Reversing Whole Loops

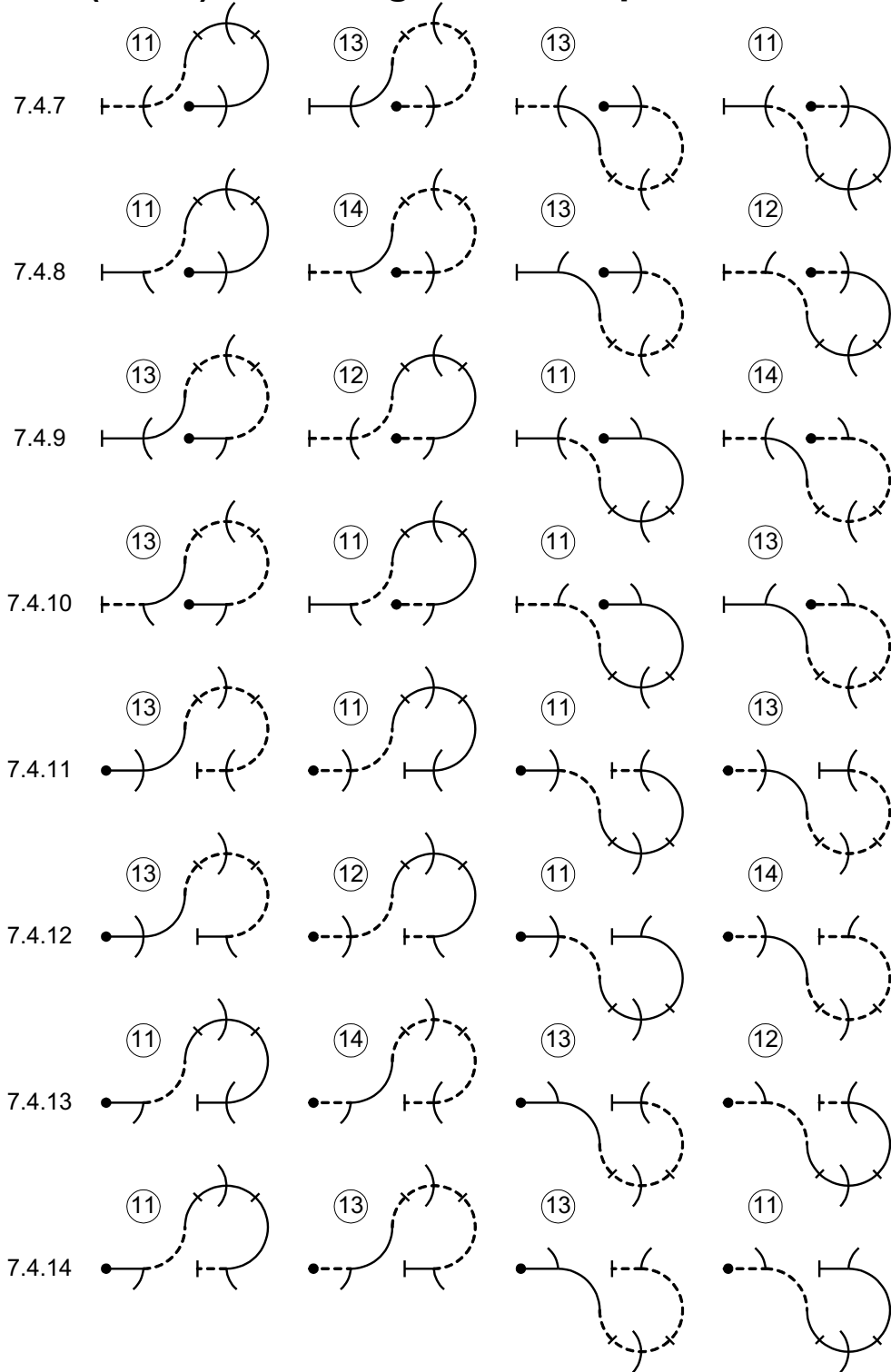

1

2

3

4

FAMILY 7 – LOOPS AND EIGHTS

ARESTI AEROBATIC CATALOGUE (CONDENSED)

Family 7.5. Horizontal "S"s

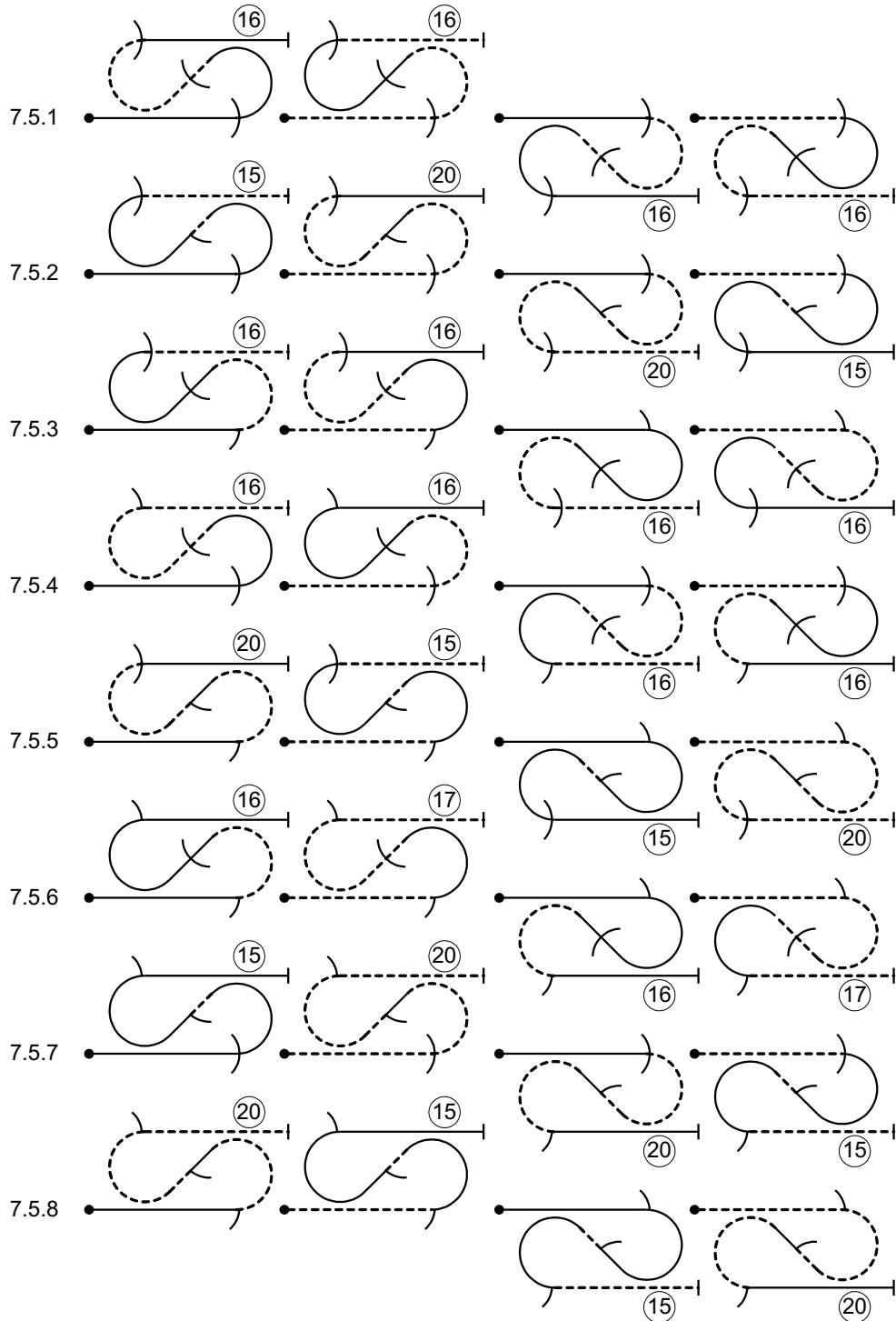

1

2

3

4

FAMILY 7 – LOOPS AND EIGHTS

ARESTI AEROBATIC CATALOGUE (CONDENSED)

Family 7.5. (Cont.) Vertical “S”s

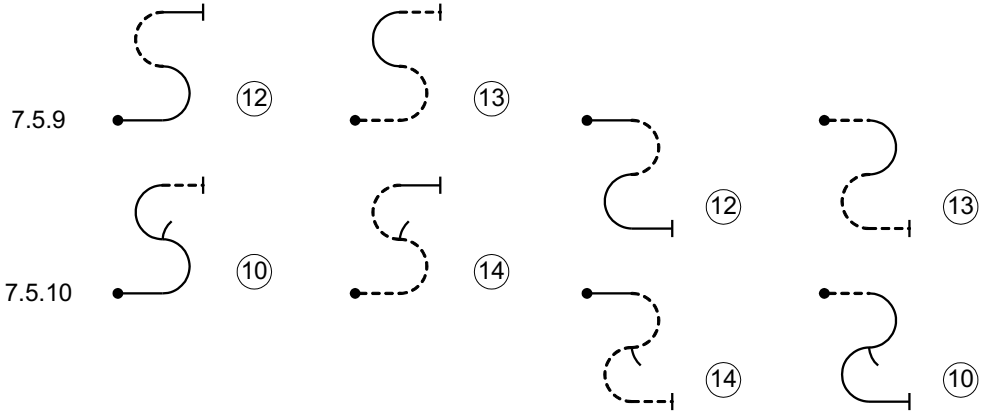

NOTE: At the sign , only half-rolls permitted.

1

2

3

4

FAMILY 7 – LOOPS AND EIGHTS

ARESTI AEROBATIC CATALOGUE (CONDENSED)

Family 7.8. Horizontal "8"s

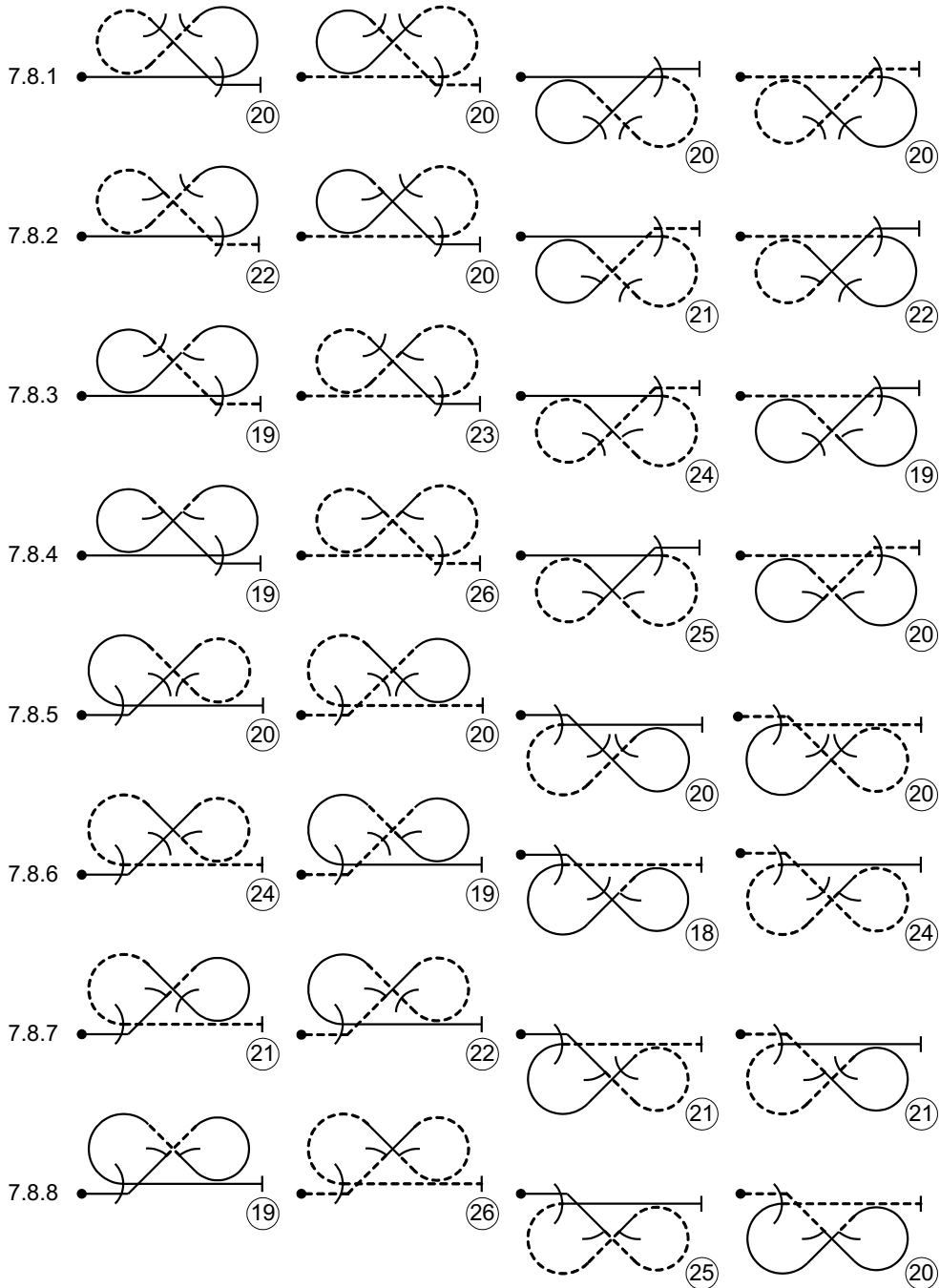

1

2

3

4

FAMILY 7 – LOOPS AND EIGHTS

ARESTI AEROBATIC CATALOGUE (CONDENSED)

Family 7.8. (Cont.) Horizontal Super "8"s

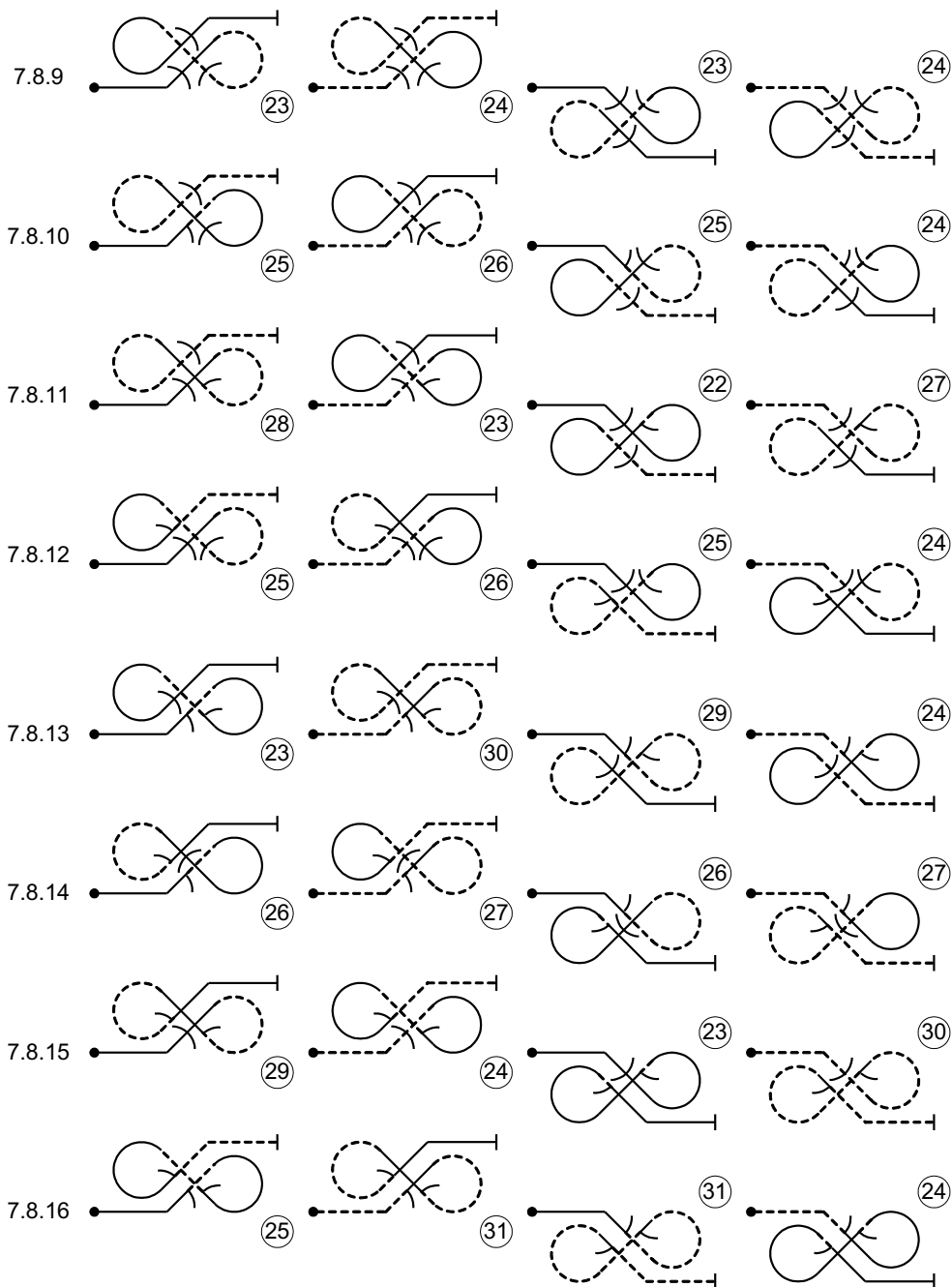

1

2

3

4

FAMILY 7 – LOOPS AND EIGHTS

ARESTI AEROBATIC CATALOGUE (CONDENSED)

Family 7.8. (Cont.) Vertical “8”s

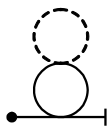
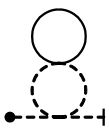
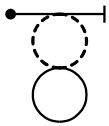
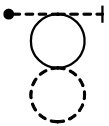
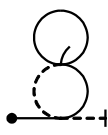
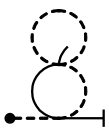
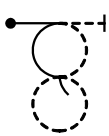
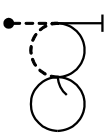
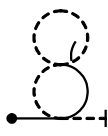
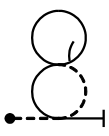
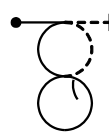
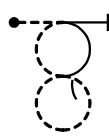
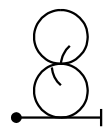
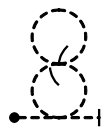
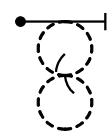
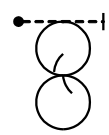
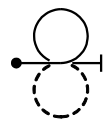
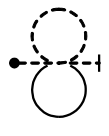
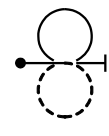
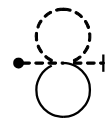
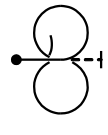
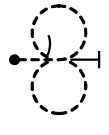
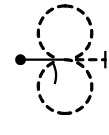
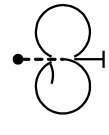
7.8.17		(22)		(23)		(22)		(23)
7.8.18		(20)		(24)		(24)		(20)
7.8.19		(24)		(20)		(20)		(24)
7.8.20		(18)		(27)		(26)		(19)
7.8.21		(22)		(23)		(22)		(23)
7.8.22		(18)		(26)		(26)		(18)
	1		2		3		4	

NOTE: At the sign , only half-rolls permitted.

FAMILY 8 – COMBINATIONS OF LINES, ANGLES AND LOOPS

ARESTI AEROBATIC CATALOGUE (CONDENSED)

Family 8.4. Humpty Bumps

(4/8ths looping segment)

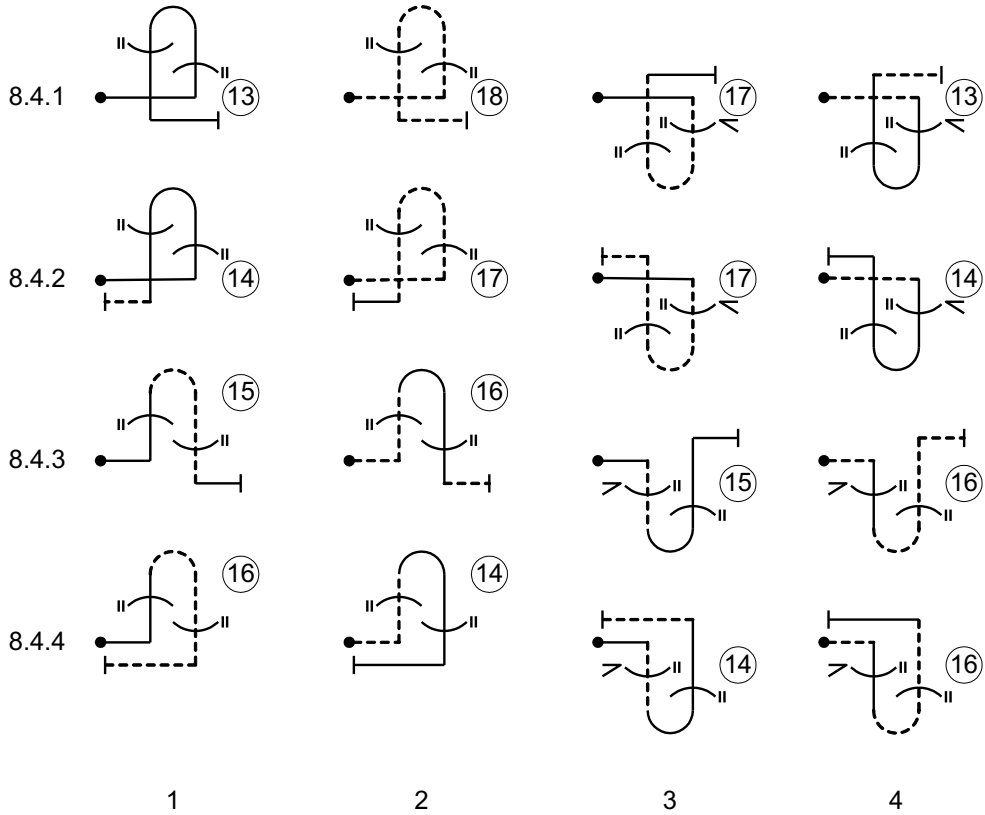

FAMILY 8 – COMBINATIONS OF LINES, ANGLES AND LOOPS

ARESTI AEROBATIC CATALOGUE (CONDENSED)

Family 8.4. (Cont.) Diagonal Humpty Bumps

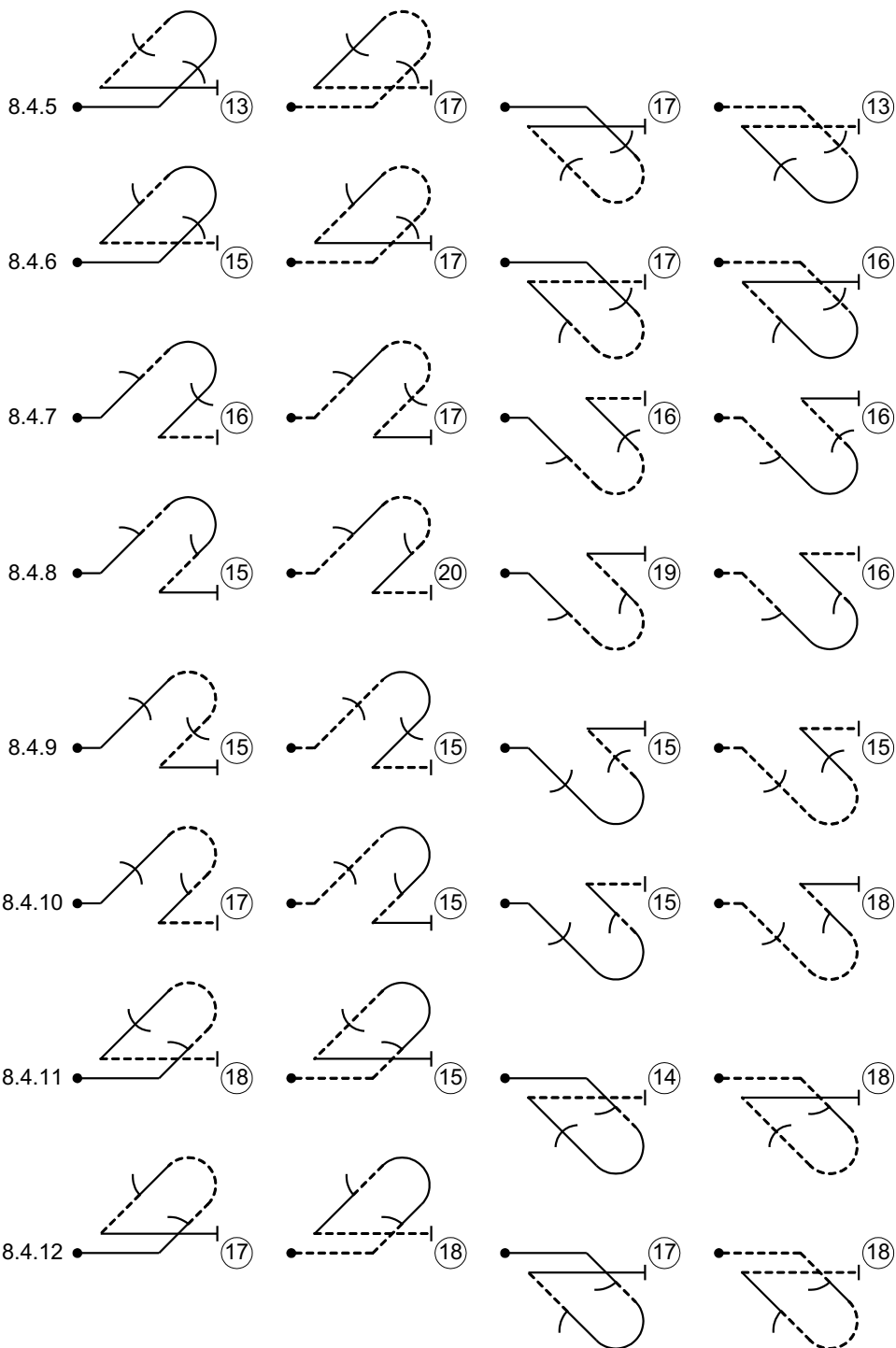

1

2

3

4

FAMILY 8 – COMBINATIONS OF LINES, ANGLES AND LOOPS

ARESTI AEROBATIC CATALOGUE (CONDENSED)

Family 8.4. Diagonal Humpty Bumps (Cont.)

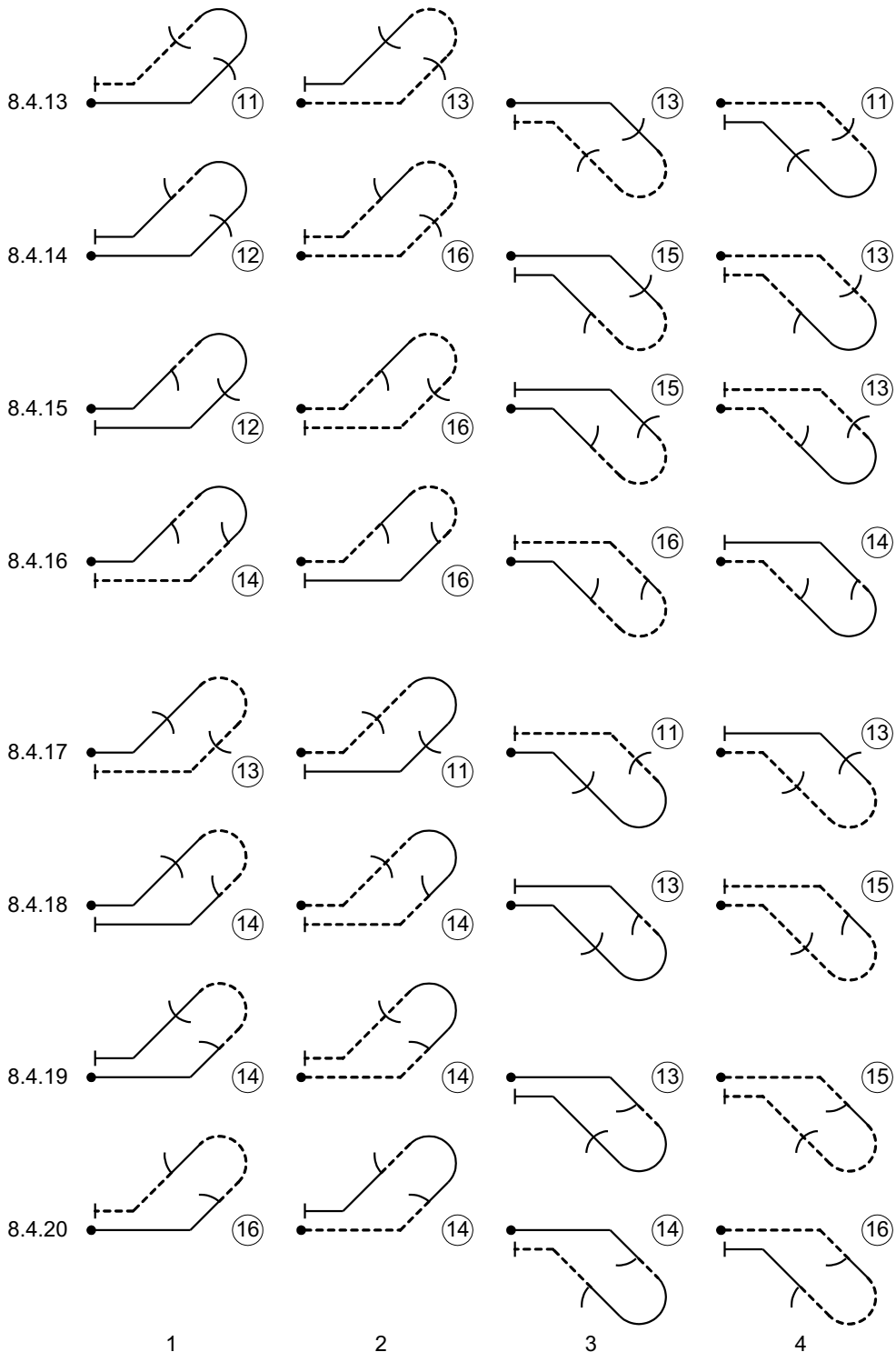

FAMILY 8 – COMBINATIONS OF LINES, ANGLES AND LOOPS

ARESTI AEROBATIC CATALOGUE (CONDENSED)

Family 8.4. Diagonal Humpty Bumps (Cont.)

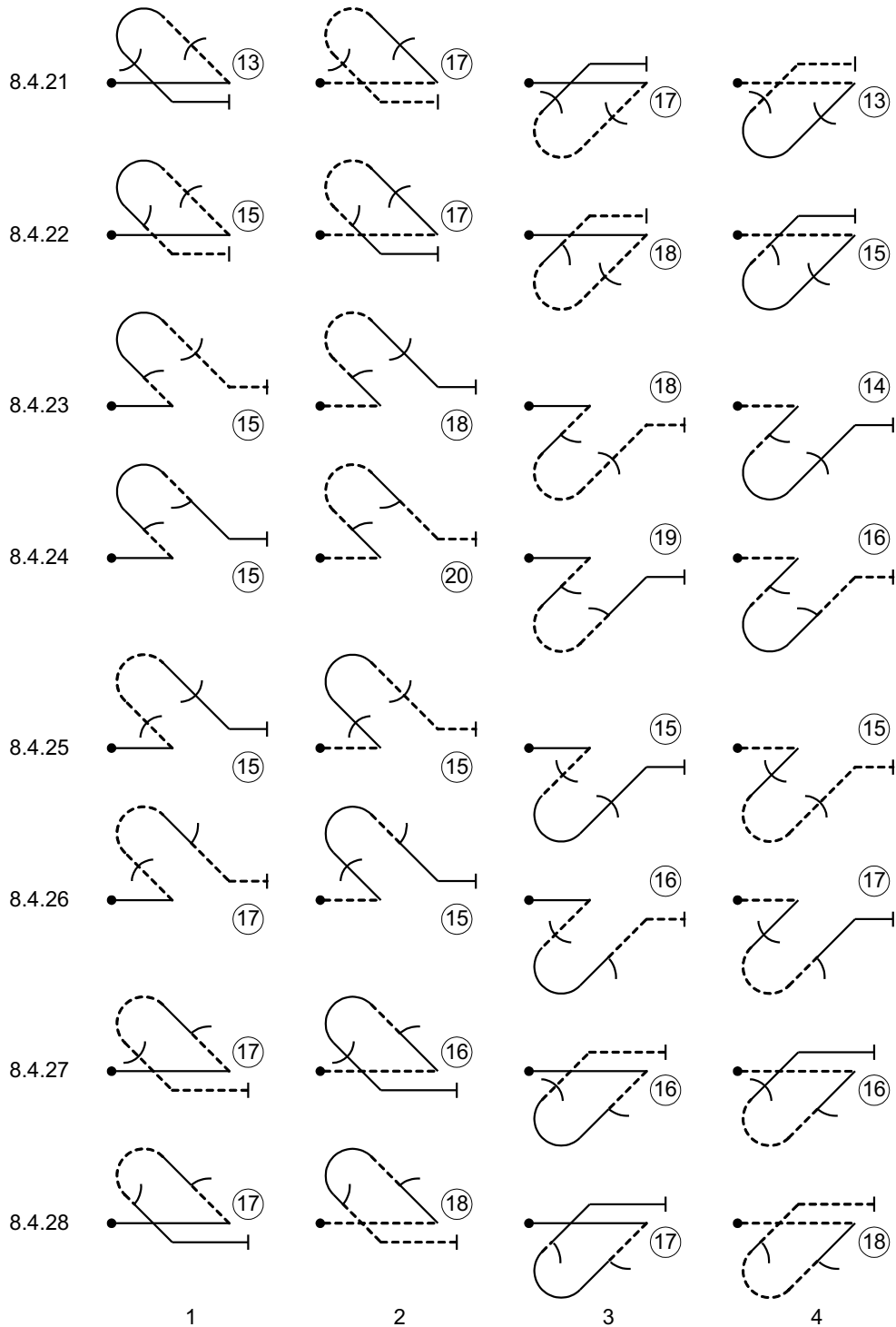

FAMILY 8 – COMBINATIONS OF LINES, ANGLES AND LOOPS

ARESTI AEROBATIC CATALOGUE (CONDENSED)

Family 8.5. Half Cubans

(5/8ths looping segment)

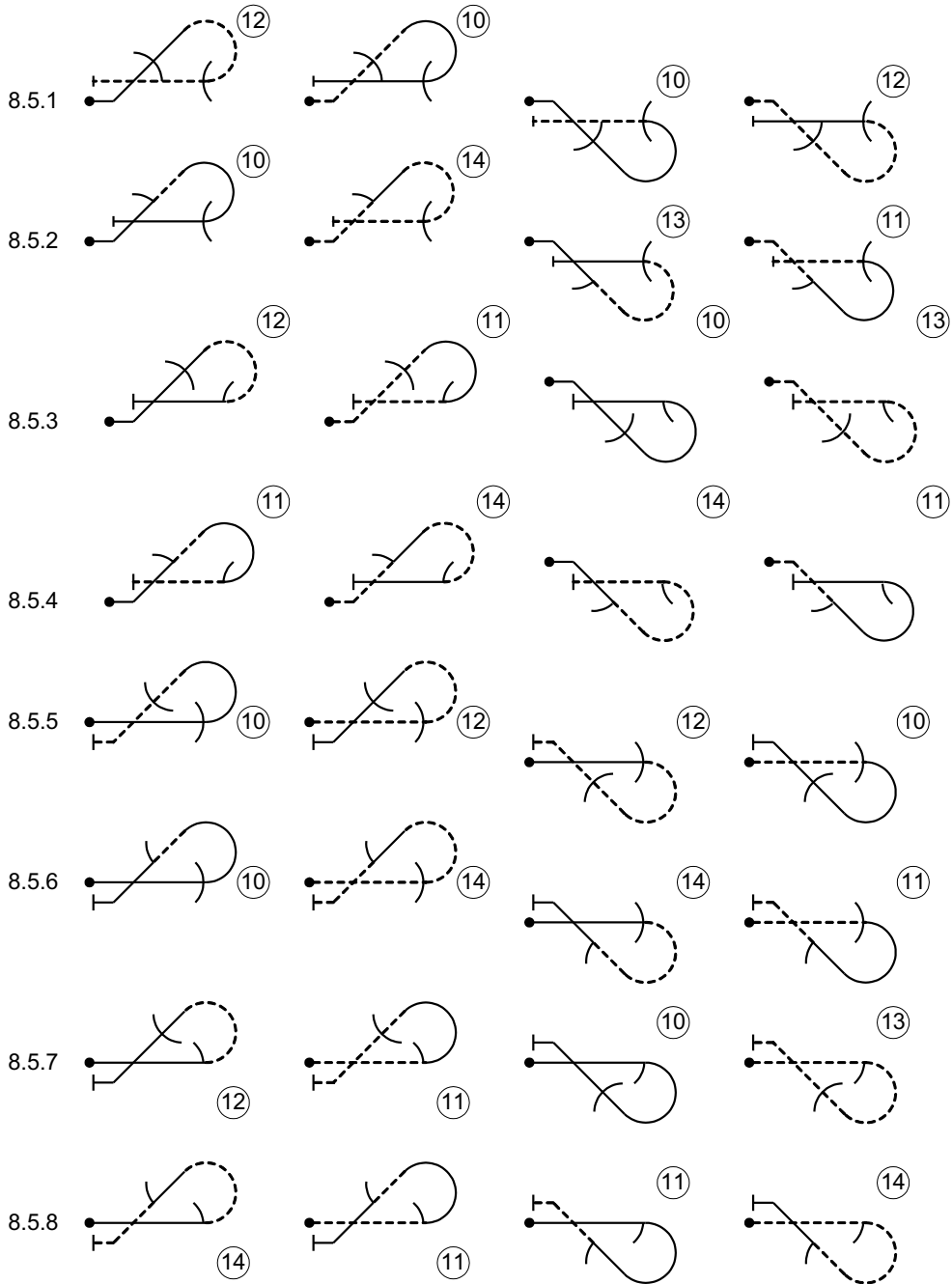

1

2

3

4

FAMILY 8 – COMBINATIONS OF LINES, ANGLES AND LOOPS

ARESTI AEROBATIC CATALOGUE (CONDENSED)

Family 8.5. (Cont.) Vertical 5/8ths Loops

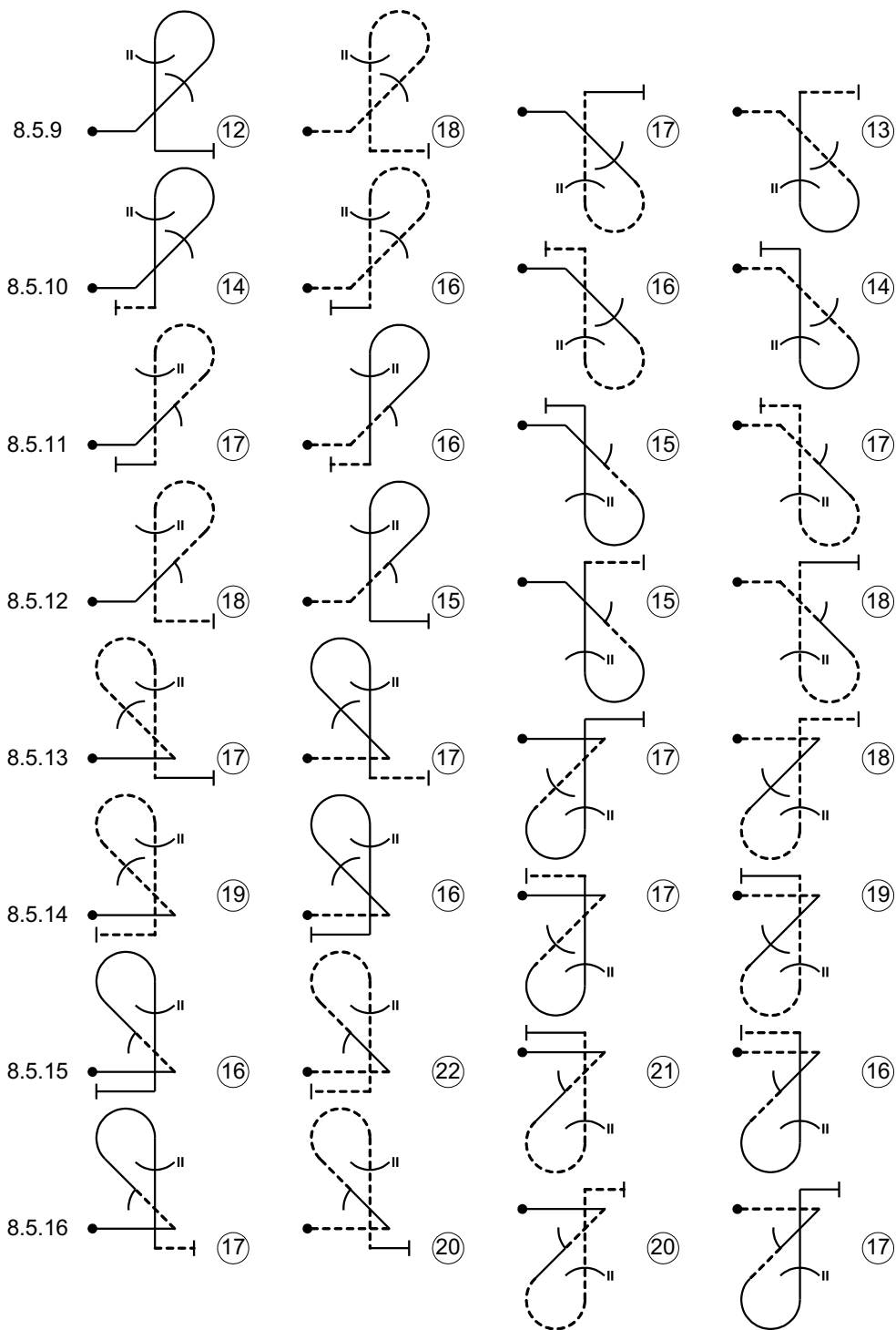

1

2











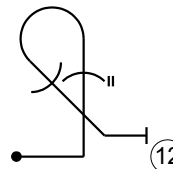
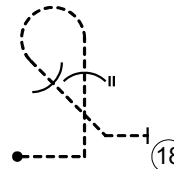
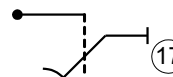
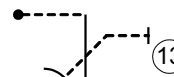
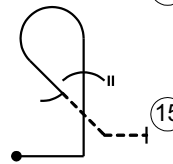
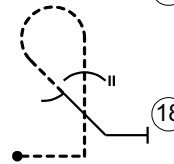

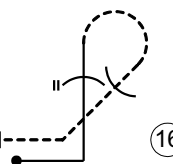
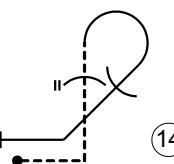

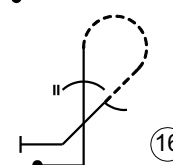
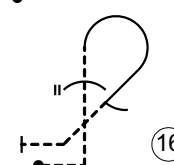
3

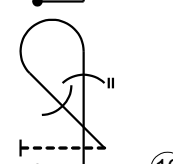
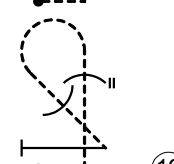
4

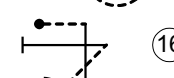
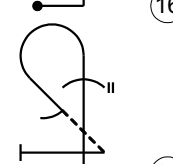
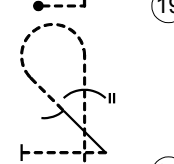
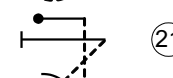
FAMILY 8 – COMBINATIONS OF LINES, ANGLES AND LOOPS

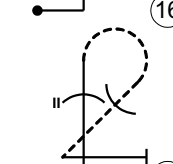
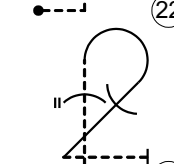
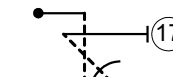
ARESTI AEROBATIC CATALOGUE (CONDENSED)

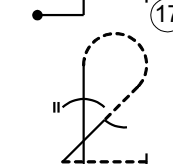
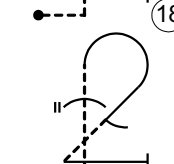
Family 8.5. (Cont.) Vertical 5/8ths Loops

8.5.17				
8.5.18				
8.5.19				
8.5.20				
8.5.21				
8.5.22				
8.5.23				
8.5.24				
	1	2	3	4

FAMILY 8 – COMBINATIONS OF LINES, ANGLES AND LOOPS

ARESTI AEROBATIC CATALOGUE (CONDENSED)

Family 8.6. "P" Loops

(6/8ths looping segment)

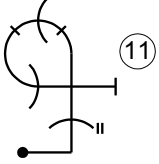
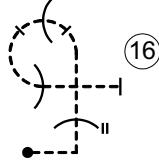
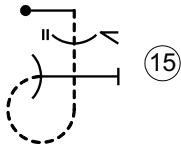
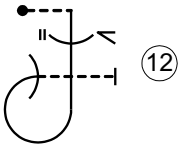
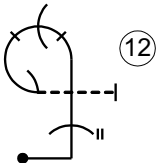
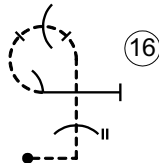
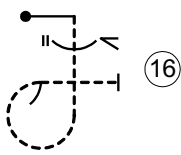
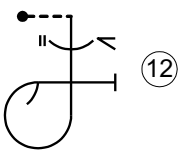
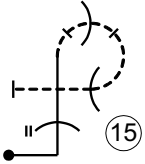
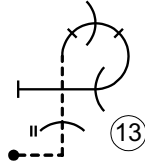
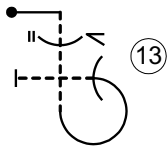
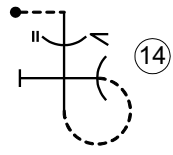
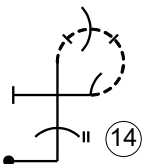
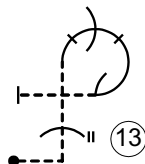
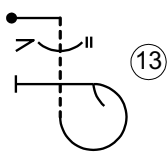
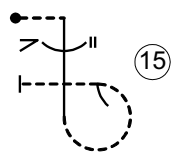
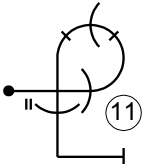
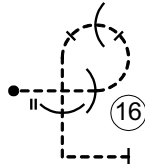
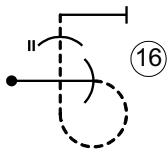
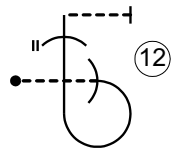
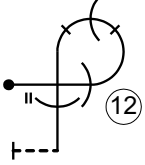
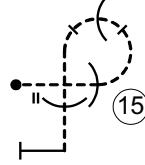
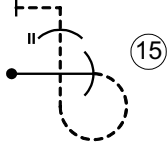
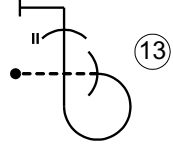
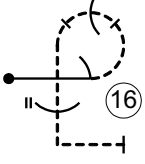
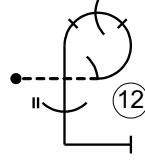
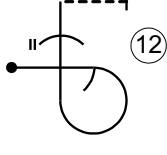
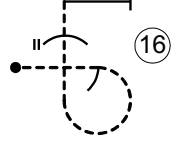
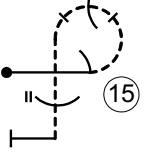
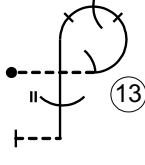
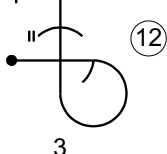
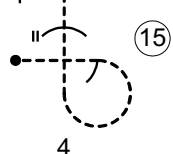
8.6.1				
8.6.2				
8.6.3				
8.6.4				
8.6.5				
8.6.6				
8.6.7				
8.6.8				
	1	2	3	4

FAMILY 8 – COMBINATIONS OF LINES, ANGLES AND LOOPS

ARESTI AEROBATIC CATALOGUE (CONDENSED)

Family 8.6. (Cont.) Reversing “P” Loops

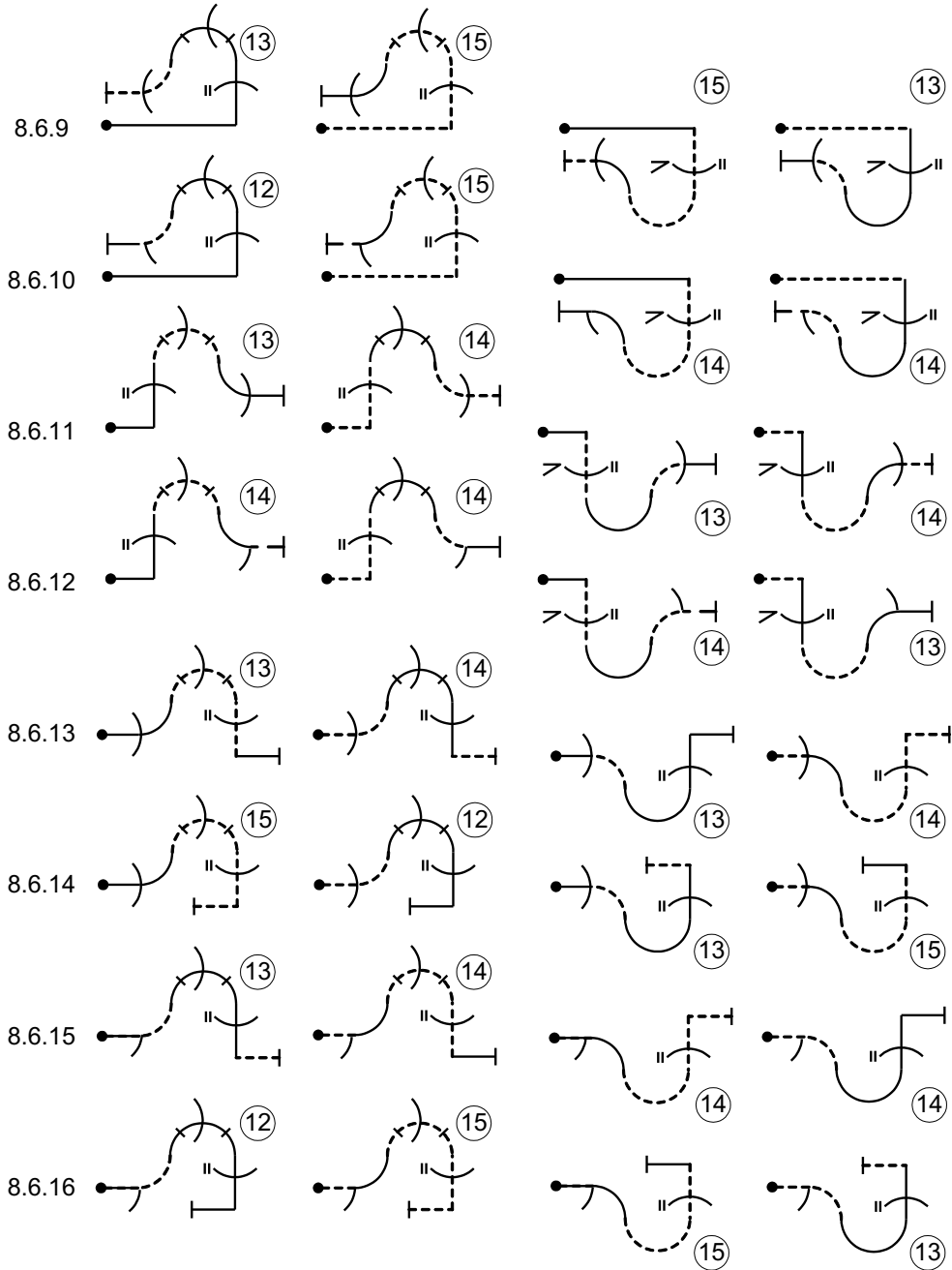

1

2

3

4

FAMILY 8 – COMBINATIONS OF LINES, ANGLES AND LOOPS

ARESTI AEROBATIC CATALOGUE (CONDENSED)

Family 8.6. (Cont.) “P” Loops

8.6.17				
8.6.18				
8.6.19				
8.6.20				
8.6.21				
8.6.22				
8.6.23				
8.6.24				
	1	2	3	4

FAMILY 8 – COMBINATIONS OF LINES, ANGLES AND LOOPS

ARESTI AEROBATIC CATALOGUE (CONDENSED)

Family 8.7. “Q” Loops

(7/8ths looping segment)

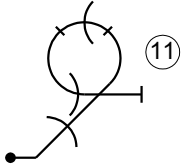
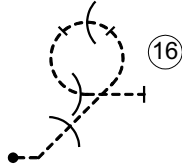
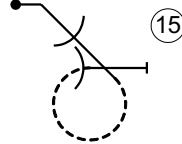
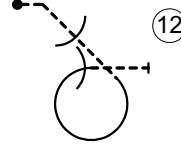
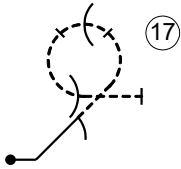
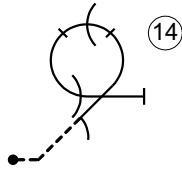
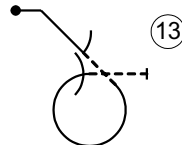
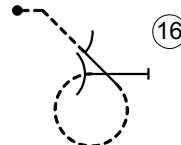
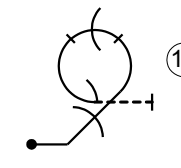
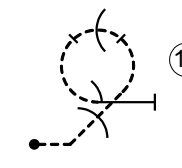
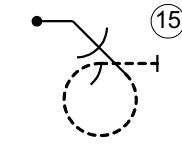
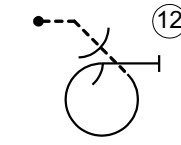
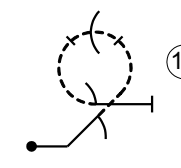
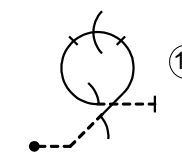
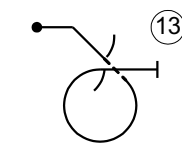
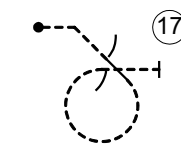
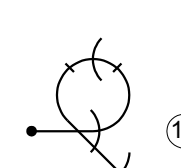
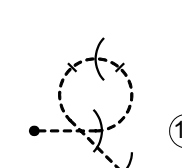
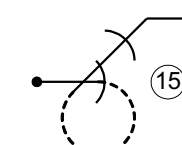
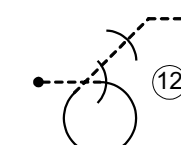
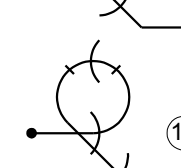
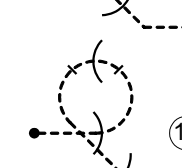
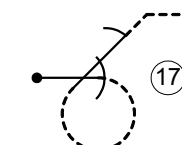
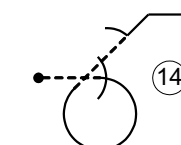
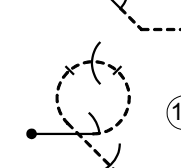
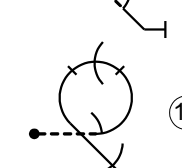
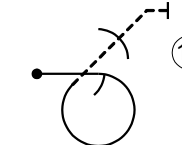
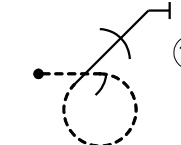
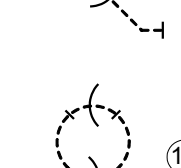
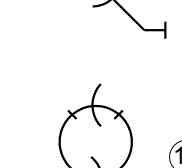
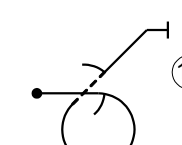
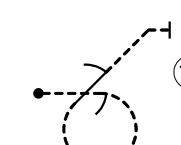
8.7.1				
8.7.2				
8.7.3				
8.7.4				
8.7.5				
8.7.6				
8.7.7				
8.7.8				
	1	2	3	4

ARESTI AEROBATIC CATALOGUE (CONDENSED)

Family 8.8. Double Humpty Bumps

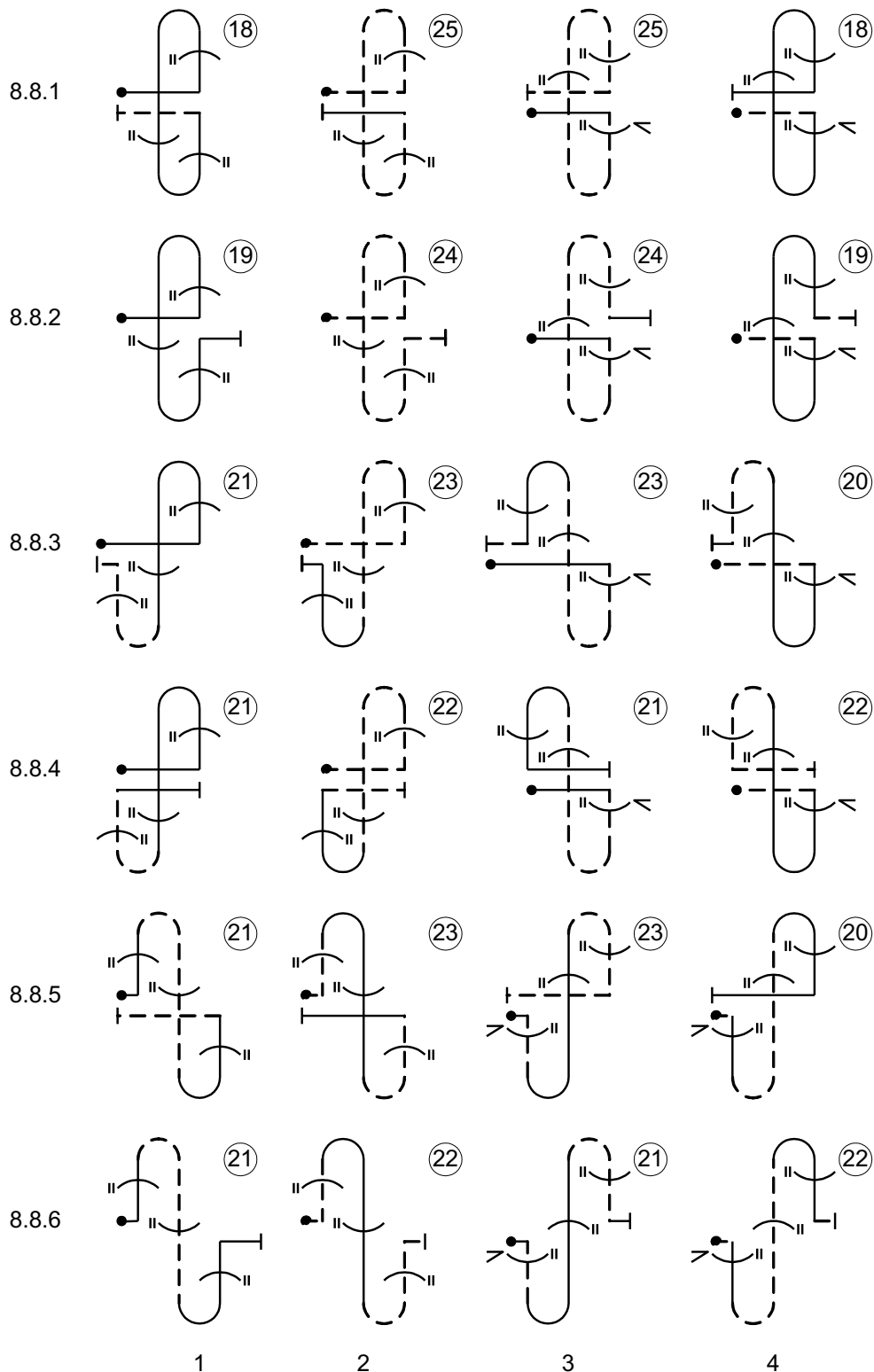

FAMILY 8 – COMBINATIONS OF LINES, ANGLES AND LOOPS

ARESTI AEROBATIC CATALOGUE (CONDENSED)

Family 8.8. Double Humpty Bumps (Cont.)

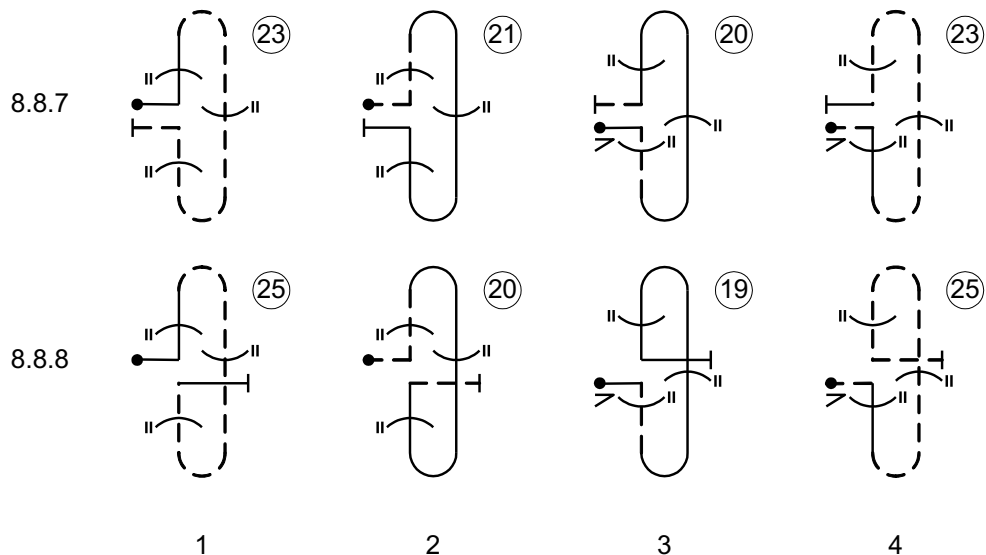



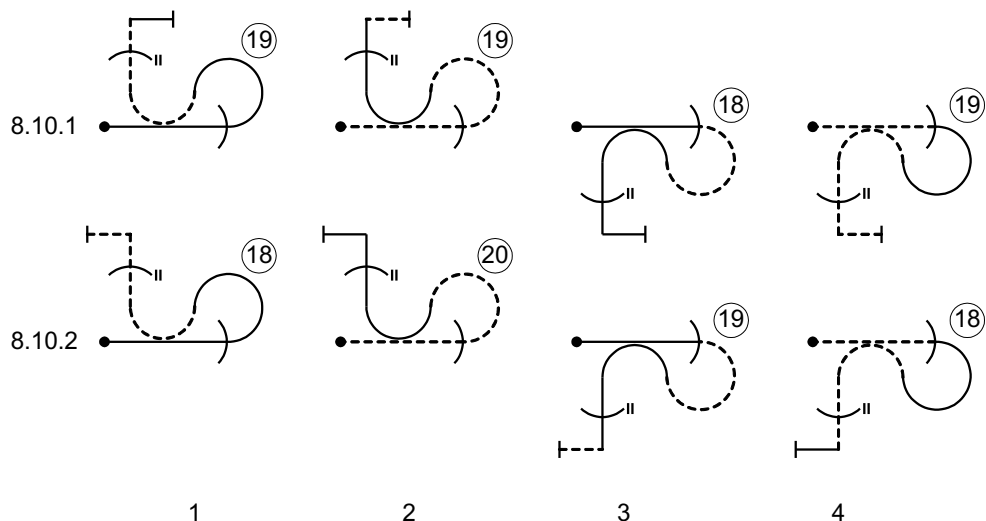

Family 8.10 Reversing 1 ¼ Loops

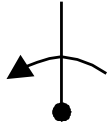

FAMILY 9 – ROLLS AND SPINS

ARESTI AEROBATIC CATALOGUE (CONDENSED)

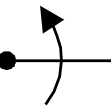
Family 9.1. (Aileron Rolls)

9.1		$\frac{1}{4}$	$\frac{1}{2}$	$\frac{3}{4}$	1	$1\frac{1}{4}$	$1\frac{1}{2}$	$1\frac{3}{4}$	2
1		6	8	10	12	14	15	17	18
2		4	6	8	10	11	12	14	15
3		2	4	6	8	9	10	11	12
4		2	4	6	8	9	10	11	12
5		2	4	6	8	9	10	11	12
		1	2	3	4	5	6	7	8

FAMILY 9 – ROLLS AND SPINS

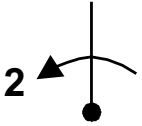
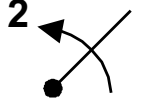
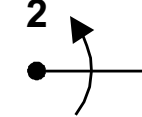
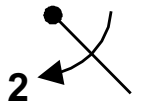
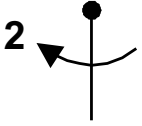

ARESTI AEROBATIC CATALOGUE (CONDENSED)

Family 9.2. (2-Point Rolls)

9.2					1		1½		2
1					13		17		21
2					11		14		18
3					9		12		15
4					9		12		15
5					9		12		15
		1	2	3	4	5	6	7	8

FAMILY 9 – ROLLS AND SPINS
ARESTI AEROBATIC CATALOGUE (CONDENSED)

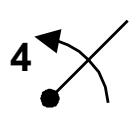
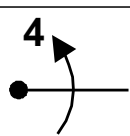

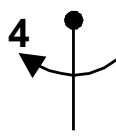

Family 9.4. (4-Point Rolls)

9.4			$\frac{1}{2}$	$\frac{3}{4}$	1	$1\frac{1}{4}$	$1\frac{1}{2}$	$1\frac{3}{4}$	2
1			9	12	15	18	20	23	25
2			7	10	13	15	17	20	22
3			5	8	11	13	15	17	19
4			5	8	11	13	15	17	19
5			5	8	11	13	15	17	19
		1	2	3	4	5	6	7	8

FAMILY 9 – ROLLS AND SPINS

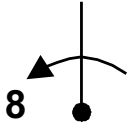
ARESTI AEROBATIC CATALOGUE (CONDENSED)

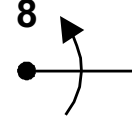

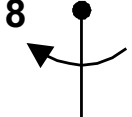







Family 9.8. (8-Point Rolls)

9.8		$\frac{1}{4}$	$\frac{1}{2}$	$\frac{3}{4}$	1	$1\frac{1}{4}$	$1\frac{1}{2}$	$1\frac{3}{4}$	2
1		7	11	15	19	23	26	30	33
2		5	9	13	17	20	23	27	30
3		3	7	11	15	18	21	24	27
4		3	7	11	15	18	21	24	27
5		3	7	11	15	18	21	24	27
		1	2	3	4	5	6	7	8

FAMILY 9 – ROLLS AND SPINS

ARESTI AEROBATIC CATALOGUE (CONDENSED)











Family 9.9. (Positive Flick Rolls)

9.9			$\frac{1}{2}$	$\frac{3}{4}$	1	$1\frac{1}{4}$	$1\frac{1}{2}$	$1\frac{3}{4}$	2
1			15	15	15	17	19	21	23
2			13	13	13	15	16	18	20
3			11	11	11	13	14	16	17
4			11	11	11	13	14	16	17
5			11	11	11	13	14	16	17
6			17	17	17	20	22	24	26
7			15	15	15	17	19	21	23
8			13	13	13	15	16	18	20
9			13	13	13	15	16	18	20
10			13	13	13	15	16	18	20
		1	2	3	4	5	6	7	8

FAMILY 9 – ROLLS AND SPINS





ARESTI AEROBATIC CATALOGUE (CONDENSED)

Family 9.10. (Negative Flick Rolls)



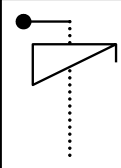

9.10			$\frac{1}{2}$	$\frac{3}{4}$	1	$1\frac{1}{4}$	$1\frac{1}{2}$	$1\frac{3}{4}$	2
1			17	17	17	20	22	24	26
2			15	15	15	17	19	21	23
3			13	13	13	15	16	18	20
4			13	13	13	15	16	18	20
5			13	13	13	15	16	18	20
6			19	19	19	22	24	27	29
7			17	17	17	19	21	24	26
8			15	15	15	17	19	21	23
9			15	15	15	17	19	21	23
10			15	15	15	17	19	21	23
		1	2	3	4	5	6	7	8

FAMILY 9 – ROLLS AND SPINS
ARESTI AEROBATIC CATALOGUE (CONDENSED)

Family 9.11. (Positive Spins)

								
			1	1¼	1½	1¾	2	
1		Upright Entry Line			5	4	3	3
			4	5	6	7	8	

Family 9.12. (Negative Spins)

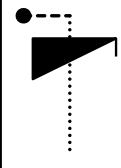
								
			1	1¼	1½	1¾	2	
1		Inverted Entry Line			7	6	5	5
			4	5	6	7	8	